

Pandora would like to thank you for choosing our DXL-3050L service and security system

Pandora is a brand of Russian Experimental Engineering Factory, a full production cycle electronics R&D facility. We design and produce car service-security systems for more than 10 years and have reached a considerable success on Russian and post-communist markets – biggest security system markets in the world. Our systems are made to withstand severe weather conditions and criminal situation of northern Eurasia.

Pandora DXL-3050L is a premium car service-security system, built for cars with on-board voltage of 12V. It is a complex engineering solution which includes car security system, telemetry, remote and automatic engine start and various service options, all accessible via RF control remote, smartphone or online service. This system is designed to be all-in-one car service and security solution and requires no additional modules: it includes algorithmic keyless bypass that works with many popular car models. For even more convenience, it allows remote control over Webasto or Eberspaecher preheaters – and even sequential use for automatic engine start.



WARNING!

IT IS STRONGLY ADVISED TO HAVE PROFESSIONAL CAR MECHANIC INSTALLING THE SYSTEM. CERTIFIED INSTALLERS ARE RARE OUTSIDE RUSSIA, BUT ANY CAR ELECTRONICS INSTALLER SHOULD BE ABLE TO INSTALL PANDORA DXL-3050L USING INSTALLATION SCHEME IN THIS MANUAL AND ALARMSTUDIO SOFTWARE. MOST FEATURES ARE HIGHLY DEPENDENT ON COMPETENT INSTALLATION. OUR SYSTEMS ARE THOROUGHLY TESTED FOR QUALITY, SO IF A FEATURE FAILS TO PRODUCE EXPECTED RESULTS, MOST LIKELY THE PROBLEM IS IN IMPROPER INSTALLATION.

It is essential for systems functioning that you read and understand instructions in this manual. Note that all radio devices are subject to interference, which could affect proper performance.

This device has limited external factors resistance. It should not be subjected to water beyond occasional splatter, or operated in temperatures outside -40 to +80 °C range.

IMPORTANT! Note that this manual describes remote and manual functions for the most part. Functionality of the system is vast and would require a book-sized manual to fully describe. Instead we use a handy software named AlarmStudio that functions as both programming tool and an extended installation & functionality manual. It requires Windows and can be downloaded at pandorainfo.com

Table of contents

General information	4
System features	4
System set	5
Control remotes	6
LED indicator signals	6
Quick access functions of the main control remote	7
Icons of remote	8
Siren sounds and turn light signals	11
Meaning of indicator LED colors	11
Control over system	12
Arming procedure	12
Disarming procedure	12
Unlocking the trunk	13
Timer channels	14
Locking/unlocking doors when the engine is running	14
Car search function	15
Delayed arming (Hands Free mode)	15
PANIC mode	16
CHECK mode, monitoring car parameters	16
Event history	17
Remote and automatic engine start	17
Engine preheater	21
Maintenance/valet mode	21
System settings menu	22
Remote sensor settings	22
Leaving connection zone notification settings	24
Siren signal settings	25
Silent mode of the remote	25
Time and alarm clock settings	26
Checking the number of recorded remotes	26
Replacing a battery in the remote	26
Arming/disarming using radio tag button	27
Arming/disarming in Hands Free mode	27
Arming/disarming in slave mode	27

Immobilizer mode	28
Antihijack mode	28
Immobilizer code using original car controls	29
Replacing immobilizer tag battery	29
Control over system in case of emergency	29

Wiring diagrams **31**

Installation and configuration of the system **35**

Wiring description	35
Programming system and entering PIN-code	37
Configuring system settings via the wireless interface 2,4 GHz	38
Entering the programming menu using VALET button	39
Changing core settings using VALET button	40
Additional devices	44

Control over system via phone **49**

Changing core settings via phone	52
Pandora online information service pro.p-on.ru and mobile apps	54

Additional information **58**

Glossary of terms	58
System modules layout	59
Warranty obligations	60
Installation certificate	61
Acceptance certificate	64
Warranty card	64

GENERAL INFORMATION

System features

Base unit

- Dialog coding of control commands.
- Individual 128-bit encryption key.
- Individual disarming PIN-code.
- RC blocking relay (2,4 GHz, frequency, up to 3 units can be connected).
- Integrated GSM-interface.
- Built-in integral accelerometer for determining motion and shocks with adaptive processing algorithm and sensitivity controls via the remote.
- Built-in 2,4 GHz aerial.
- Advanced process of sensor data reading, eliminating false alarm possibilities.
- Automatic arming.
- Registers delay for interior lighting when arming.
- Hands Free mode for arming/disarming without using a remote.
- Software updates via built-in micro-USB socket.

Immobilizer tags

- Dialog coding of control commands.
- Individual 128-bit encryption key.
- Built-in LED indicator.
- Built-in button to control over security modes.
- CR-2032 battery.

Car security zones

Pandora DXL-3050L service-security system guards following independent zones with corresponding zone notifications on the remote and recording alarms into the event history:

- car doors perimeter (separate for every door)
- front hood triggers
- trunk triggers
- ignition trigger

- brake pedal button
- triggering of the shock sensor (warning level)
- triggering of the shock sensor (alarm level)
- triggering of the motion sensor
- triggering of the tilt sensor
- critically low on-board voltage
- marker lights left on notification when arming*

System set

1. Base unit	1
2. Main control remote with LCD	1
3. Tag 2,4 GHz	1
4. Leather case for tags	1
5. Main cable	1
6. Cable with VALET button and three-colored light indicator	1
7. Siren	1
8. Fastening kit	1
9. User installation manual	1
10. Plastic card with individual secret code	1
11. Packaging	1
12. Beeper (compact sound emitter)	1
13. Microphone	1
14. Relay module	1
15. Engine compartment module	1

Manufacturer reserves the right to change set and construction of the product to improve its technological and operational parameters without notification.

* Availability of this function depends on car make and model

Control remotes

Two-way remote is the main mean of control over the system.

For easily distinguishable notifications the remote uses 16 ringtones. Each ringtone matches particular event.

Remote has flashing LED indicators for additional information. The remote is fully operational when shipped. To switch the remote on press and hold **F III** button for 3 seconds. **'REMOTE ON'** ringtone will play. Pressing and holding this button again for 3 seconds will cause the remote to switch off.

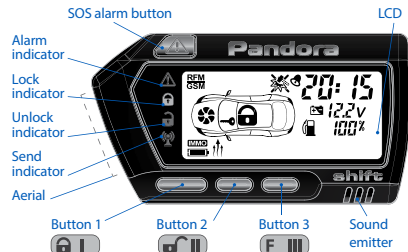

WARNING!
ALL CONTROL COMMANDS ARE TRANSMITTED VIA RADIO CHANNEL, FOR MAXIMUM EFFECTIVENESS AND RANGE IT IS RECOMMENDED NOT TO SHIELD AERIAL AREA (SEE PICTURE) WITH FINGERS WHEN USING A REMOTE.



WARNING!
REMOTE IS A UNIFIED CONTROL DEVICE. REMOTE CONTROL FUNCTIONS DEPEND ON SECURITY SYSTEM MODEL.

LED indicator signals

Red Alarm indicator

- Flashes frequently when any notification.
- Flashes when any alarm notification.

Green Lock indicator

- Flashes occasionally if system is armed.

Red Unlock indicator

- Flashes occasionally if system is not armed.

Red Send indicator



- Flashes occasionally if there is no connection.





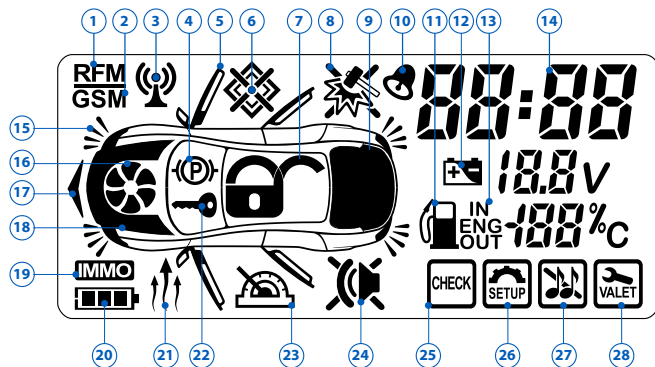







Quick access functions of the main control remote













	System disarmed		System armed
	Engine is running	Engine is stopped	
I (short press)	Lock doors without arming	Arming with sound confirmation	Search mode – car will flash turn signals and sound horn for 5 seconds
I (1 sec.)		Arming without sound confirmation	Search mode – car will flash turn signals without any sounds for 5 seconds
I (2 sec.)	Switch on ignition support		
I (3 sec.)	Switch on programmed neutral		Remote engine start
II (short press)	Unlock doors	Unlock doors	Disarming with sound confirmation
II (1 sec.)		Unlock doors	Disarming without sound confirmation
II (>2 sec.)	Switch off ignition support		Switch off ignition when turbo timer, remote or automatic engine start is active
III (short press)	Switch on LCD lighting (available only on the remote with LCD)		
III (1 sec.)	Unlock trunk (CH1)		
III (2 sec.)	Switch on/off timer channel (CH2)		
III (3 sec.)	Switch on/off remote (available only on the remote with LCD)		
I + II (short press)	PANIC mode		
I + III (short press)	Arming when the engine is running with sound confirmation	Arming in 30 seconds (Hands Free mode) with sound notification	
I + III (1 sec.)	Arming when the engine is running without sound confirmation	Arming in 30 seconds (Hands Free mode) without sound notification	

Icons of remote



1. **RFM** Flashes if there is no connection to the base unit
2. **GSM** GSM connection indicator (for systems that are equipped with GSM-modem)
3.  Sending command indicator
4.  Handbrake/neutral indicator, brake pedal security zone
5.  Door security zone. Separate for each door (if there is separate control via digital bus)

6.  Original security system status
7.  Security mode status (armed/disarmed)
8.  Shock sensor security zone
 -  Warning level of the sensor
 -  Alarm level of the sensor
 -  Warning level zone monitoring disabled
 -  Shock sensor monitoring disabled
9.  Trunk security zone
10.  Alarm clock
11.  Fuel left
12.  Car battery voltage, voltage security zone
13.  Interior, engine and exterior air temperature
14.  Numeric indicator. Displays current time

- 15.  Light signalization (using marker lights, turn signals)
- 16.  Engine operation icon
- 17.  Motion sensor security zone
- 18.  Front hood security zone
- 19. **IMMO** Locking of the engine enabled
- 20.  Remote battery level
- 21.  Engine preheater
- 22.  Ignition, ignition security zone
- 23.  Tilt sensor security zone
- 24.  Silent mode of the system
 - Warning signals of the system disabled
 - All sound signals disabled
- 25.  Check current state and enter event history
- 26.  System settings
- 27.  Silent mode of the remote (MUTE)
- 28.  Car maintenance mode

Siren sound and turn light signals

Signal name	Signal description
Alarm mode, PANIC mode	Incessant sound and light signals for 30 seconds
Arming	1 sound and 1 light signals
Disarming	2 sound and 2 light signals
'Sensors triggered' signal when disarming	4 sound and 4 light signals
'Sensor malfunction' signal when arming	4 sound and 4 light signals
Sensor warning level triggered	3 sound and 1 light signals
Car search	5 sound and 5 light signals

Meaning of the indicator LED colors

Indicator status	Meaning
Short red flashes	The system is armed
Lit red	The system is preparing for automatic arming
Orange flash	Confirms VALET button press
Orange flashes	Confirms a number of recorded remotes (when switching on ignition)
Green flashes	Confirms a number of recorded tags (when switching on ignition)
Red and green flashes	PIN-code confirmed
Faded	The system is disarmed

CONTROL OVER SYSTEM

Arming procedure

Arming the system allows monitoring of all security zones, locks the doors and blocks the engine.

To arm the system when the engine is stopped, shortly press **[A]** button on the remote. The siren will sound and turn signals will flash once. The remote will play **'ARMING'** ringtone and security mode status icon (the lock) will change to: 

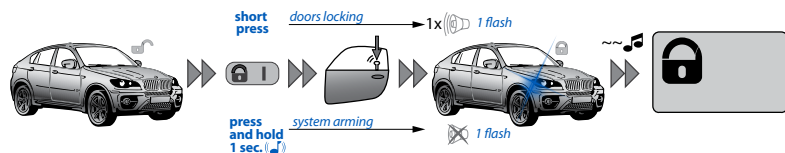



For arming without sound confirmation press **[A]** for more than 1 second.

If when arming doors, hood or trunk were open, the siren will sound 4 short signals instead of 1, turn signals will flash 4 times, remote will play **'WARNING!'** ringtone (after **'ARMING'** ringtone) and will show troubled zone. This zone sensor will be disabled at that moment. Sensor will be armed again in 15 seconds after the zone was set right.

For emergency arming when engine is running, press and hold VALET button for 3 seconds until the system confirms with red LED indicator flash. A car will be armed in 30 seconds.

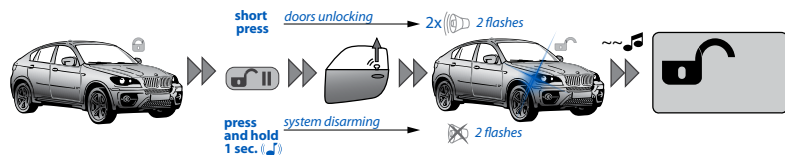
Disarming procedure



To disarm the system, shortly press **[B]** button on the remote. You will hear 2 short siren sounds and will see 2 flashes of turn signals. The remote will play **'DISARMING'** ringtone and security mode status icon will change to: 

For disarming without sound confirmation press **[B]** button for more than 1 second.

If there were new alarming events during the time system was armed, siren will sound 4 times, and turn signals will flash 4 times, the remote will sound **'WARNING!'** ringtone (after **'DISARMING'** ringtone) and will indicate zones triggered. All recent alarm events can be viewed in the event history.

Unlocking the trunk

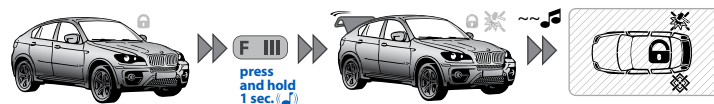







To independently unlock the trunk, no matter if the system is armed or not, press **[F]** button and hold it for 1 second.

If the system is armed when this action is performed, the trunk will be disarmed, shock and supplementary sensors of the trunk will be disabled. All the other security zones will remain armed.

If in 15 seconds after using **'Unlock trunk'** command, the trunk was not opened, the system will lock it again, enable sensors and arm trunk security zone. This will be indicated with 1 flash of turn signals.

Timer channels

Timer channels (see glossary) control additional or original devices in automatic mode (on particular events) or directly from the remote.



To activate any timer channel, select  icon with short presses of  button, then press  shortly. Select channel's number with short presses of . To switch on any channel, shortly press  or press  to switch off.

Press and hold  button for 2 seconds to get quick access to Timer channel 2 (CH2).



WARNING!
TIMER CHANNELS CAN BE SWITCHED ON FROM REMOTE ONLY IF SYSTEM SETTINGS ALLOW IT.

Locking/unlocking doors when the engine is running

The system controls doors locking when the engine is running. To lock doors, shortly press  arming button, to unlock doors, press  disarming button.

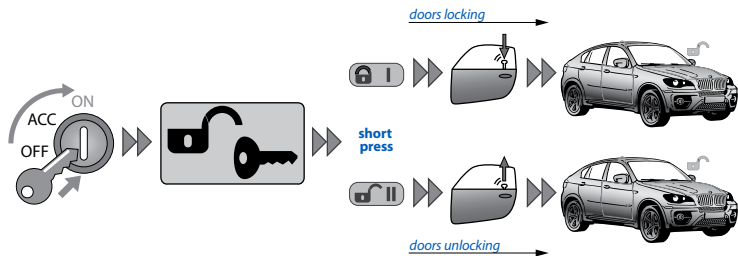

There is an automatic movement lock mode that will lock the doors at the car movement and will unlock them when the ignition is being switched off. In no less than 5 seconds after the ignition was switched on, the doors will be locked automatically when the car starts moving, and unlocked when the ignition will be switched off (programmable). If any door was opened after the ignition had been switched on, automatic locking will be disabled to prevent locking the keys inside the car.

Car search function

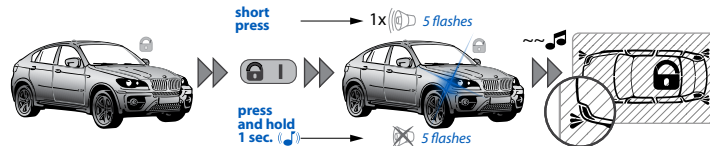



To easily find your car on a massive parking, shortly press  when the car is armed. The system will sound the siren and flash turn signals 5 times in a row.

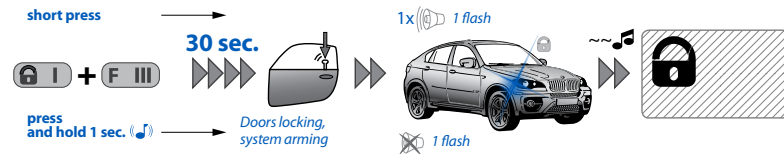

To search for car without sound confirmation, press and hold  button for more than 1 second.

Delayed arming (Hands Free mode)



If when leaving the car you cannot arm it using a remote (you have your hands full), you can use **delayed arming**.

To activate this mode, shortly press  and  simultaneously. LED indicator will turn red, the system will lock doors and will arm in 30 seconds, siren will sound and turn signals will flash once, indicating that the mode is triggered.

To activate this mode without sound confirmation, press and hold both  and  for more than 1 second until the sound and vibration signal.

To cancel delayed arming when it is triggered, simply press .

PANIC mode

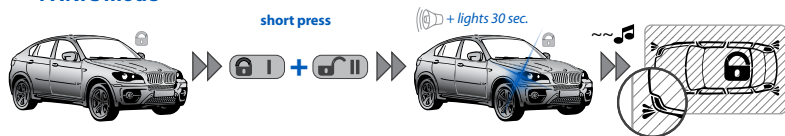

If your car or you are in danger and you want to draw attention to your car, you can use **PANIC mode**. In this mode the siren will sound and turn signals will flash repeatedly for 30 seconds. To trigger PANIC mode, press 🔒 and 🔓 simultaneously. To switch it off, press either 🔒 or 🔓.

CHECK mode, monitoring car parameters

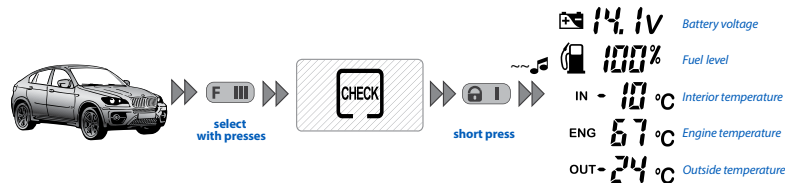

To receive information about engine temperature, interior temperature and on-board voltage, press F III button, select CHECK icon and shortly press 🔒 button.

For 10 seconds, numeric indicator will be sequentially showing interior temperature (IN - 10 °C), engine temperature (ENG 67 °C), outside temperature (OUT - 24 °C) and battery voltage (EV 14.1V). To exit this mode, shortly press F III button, otherwise it will end automatically in 10 seconds.

NOTE: Temperature will only be shown if temperature sensor is connected. The sensor availability depends on the system set. Fuel level will only be shown if it can be read from CAN-bus.

Event history

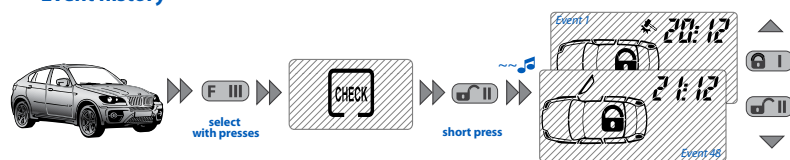

To view event history in the system's memory, press F III button and select CHECK icon, then shortly press 🔒 button.

Navigate several last events using 🔒 (forward) and 🔓 (back). Events are displayed by showing time of the event and flashing corresponding trigger zone indicators. To exit this mode, press and hold F III for 1 second.

Remote and automatic engine start

The system allows for **remote engine start** using remote engine start command or **automatic engine start** using preconfigured automatic engine start function. Remote start can be used to heat engine and interior, charge battery or to cool the interior with air conditioning.

Remote and automatic start can only be used when the system is armed.

If the car has manual transmission, remote or automatic start will only occur if **programmed neutral procedure** was followed when the car was arming.

Remote and automatic engine start on automatic transmission cars will only occur, if transmission selector lever was left in a 'P' position.

When using remote and automatic engine start functions, make sure that the car is secured with handbrake or some other means of fixating the car on a parking position.

While system is in remote and automatic start mode, it keeps performing all security functions save for shock sensor, which will have lower sensitivity during engine start and for a short time after while algorithm adjusts to the new normal.

To compensate, motion sensor sensitivity, responsiveness and range will be increased. If any security zone will be triggered, the engine will be immediately stopped and alarm mode will be entered. Herewith all immobilizer functions will be activated.

Programmable neutral procedure (for cars with manual transmission)

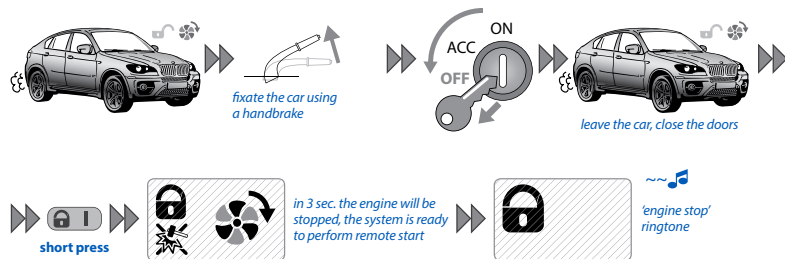

If you are planning to use remote and automatic engine start on a car with manual transmission, before arming you will need to perform following actions:

1. While the engine is running, fixate the car with the handbrake and put manual transmission lever (shift-stick) to the neutral position.
2. Turn the key in the ignition lock to the **OFF** position (**the engine should still be running**) and take it out of the lock.
3. Leave the car, close the doors.
4. Press button to arm the car and lock the doors. On LCD remote the engine operation icon will be spinning and security mode status icon will light.
5. The engine will be stopped. Now the system is ready to perform remote and automatic engine start.

Remote engine start

If the system is prepared for remote start, to execute it, press and hold for 3 seconds. Sound signal will confirm the command, LCD will show crossed out shock sensor icon and flashing

engine operation icon signifying preparation to the engine start. In a few seconds the engine will be started, the remote will play 'ENGINE START' ringtone and show spinning engine operation icon .

Engine operation duration depends on system settings – either heating time or threshold temperature for engine stop.

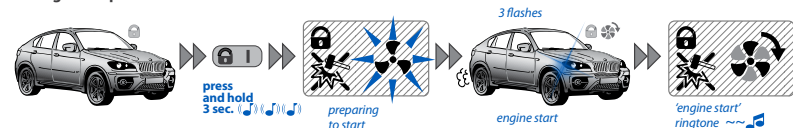

To remotely stop the engine while it performs heating, press and hold for 2 or more seconds. The engine will be immediately stopped and it will be confirmed by remote playing 'ENGINE STOP' ringtone and engine operation icon fading.

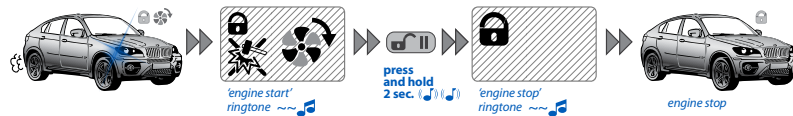

The remote will give notification 1 minute before designated engine stop: icon will flash and 'ENGINE STOP IN 1 MINUTE' ringtone will play every 10 seconds.

If the engine was started using remote or automatic start, remote engine start command will extend its operation period by 10 minutes.

This procedure can be repeated multiple times.

Automatic engine start

The system allows setting up modes of automatic engine start and stop. Synchronized real-time clock on the remote and base unit and other autonomous system settings allow many engine start options without needing to have the remote in command radio range.



WARNING!
ONLY ENABLE REMOTE START IF YOUR LOCAL LEGISLATION ALLOWS DRIVERLESS CARS TO HAVE WORKING ENGINE.

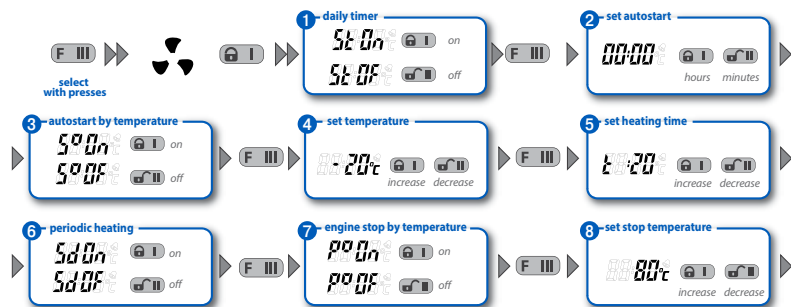

If you have not confirmed with this button press, remote start settings will remain the same as before.

Automatic start and engine work conditions programming is done using LCD remote. Select icon by pressing (F III) button and press (I) button to enter remote start functions menu. This menu has 8 sub-levels that can be rotated by pressing (F III). Sub-level values are changed using (I) and (II).

When done changing settings, the values should be saved. To do this, press (Δ) button. The changes will be sent to the base unit, confirmed by the double sounding of short sound signal.

NOTE: If you have not saved new settings, remote and automatic engine start settings will remain the same as before.

- To proceed to the following engine setting level, shortly press (F III) button.
- To exit setting mode, press and hold (F III) button for 1 second (or it will end automatically in 10 seconds), herewith changed settings will not be saved.

NOTE: Engine start via temperature is available only if temperature sensor is connected. The sensor availability depends on the system set.

Engine preheater

To switch on engine preheater, select icon by pressing (F III) button and then shortly press (I) button. Sound notification will confirm reception of command. If preheater monitoring is connected and enabled, LCD will display during engine preheater operation.

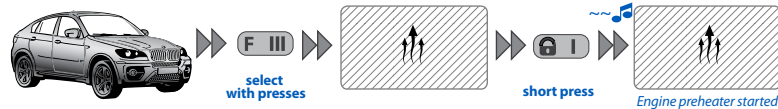

To switch off engine preheater using a remote, select icon by pressing (F III) button and confirm by shortly pressing (II) button. Sound notification will confirm reception of command. LCD will display .

Maintenance/valet mode

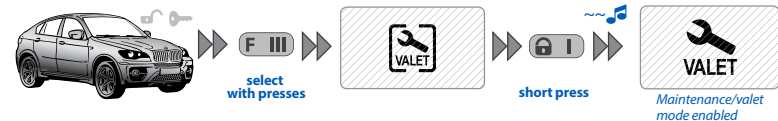

It is recommended to put system into maintenance mode before handing it to the car service or valet parking. When this mode is switched on, security system stops interfering with built-in electronics and disables all functions to ease maintenance or parking. Moreover, you will not have to leave the remote to the valet or the mechanic. This feature is implemented to prevent recording additional remotes during maintenance without the owner knowing.

To activate maintenance mode while the engine is running, select icon by pressing (F III) button and confirm by shortly pressing (I) button. The system will confirm enabled valet mode with green flash of LED indicator when engine is running. To exit maintenance mode, select icon by pressing (F III) button and confirm by shortly pressing (II) button.

NOTE: If immobilizer/Antihijack mode is active, the remote must be in range to switch on valet mode.

System settings menu

Main system parameters and settings can be changed using LCD remote. To enter the settings menu, select icon by pressing (F III) button and confirm by pressing (A I) button for 1 second. To cycle between sub-levels of settings, use (F III) button, to enter sub-level of settings, press and hold (A I) for 1 second.

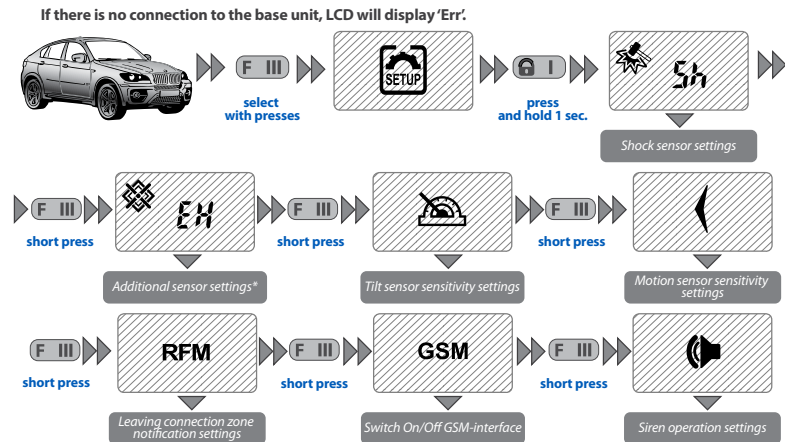

Remote sensor settings

Shock sensor control and sensitivity settings

For prompt remote adjustment of alarm and warning levels of the shock sensor enter the settings menu, select icon with (F III) button presses and press (A I) button for 1 second. Press (F III) button to cycle between control and sensitivity settings of warning and alarm sensor levels. icon

* Additional sensors control is not supported by this model.

and left part of the numeric indicator will flash indicating that alarm level of shock sensor is being adjusted. Short presses of (A I) button will increase the sensitivity of the alarm level (i.e. sensor will trigger from smaller impacts), short presses of (A II) button will decrease the sensitivity of the alarm level of the shock sensor.

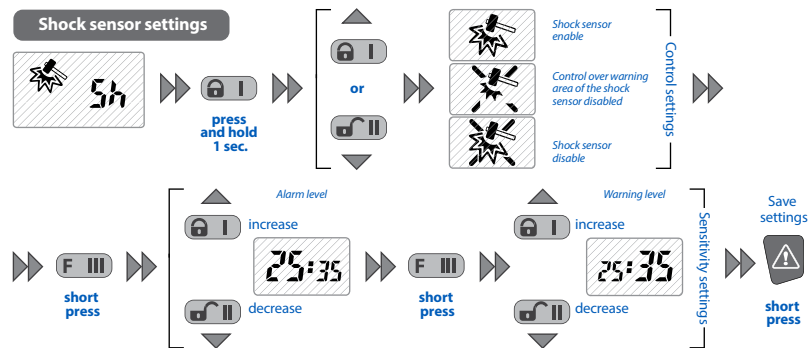

Short presses of (F III) button will switch between sensitivity settings of warning and alarm levels of the shock sensor. To save the new sensitivity values of the shock sensor, shortly press . To exit this mode without saving, press and hold (F III) button for 1 second, otherwise it will end automatically in 10 seconds.

Max sensitivity value of warning and alarm level of sensors is 50.

Motion/tilt sensor sensitivity settings

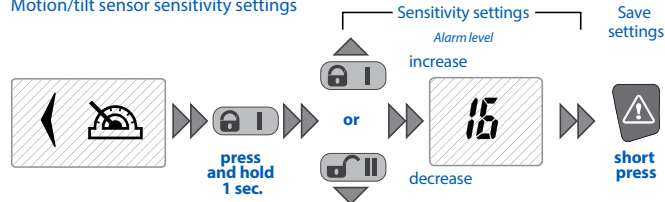

For prompt remote adjustment of alarm and warning levels of the motion sensor enter the settings menu, select icon with (F III) button presses and press (A I) button for 1 second.

To save the new sensitivity values of the tilt sensor, shortly press . To exit this mode without saving, press and hold (F III) button for 1 second, otherwise it will end automatically in 10 seconds.

Max sensitivity value of motion and tilt sensors is 50.

Leaving connection zone notification settings

When the owner with the remote leaves the range of system's radio connection, there are three possible notification options. To set up one of the options, enter the settings menu, select **RFM** icon by pressing (F III) button and confirm by pressing (A I) for 1 second. With short presses of (A I) or select one of three notification options:

- RFM disable notifications;
- RFM enable notification with 'SIGNAL LOST' ringtone;
- RFM enable notification with alarm signals.

To exit and save the new settings, press button. To exit this mode without saving, press and hold (F III), otherwise the menu will be exited automatically in 10 seconds.

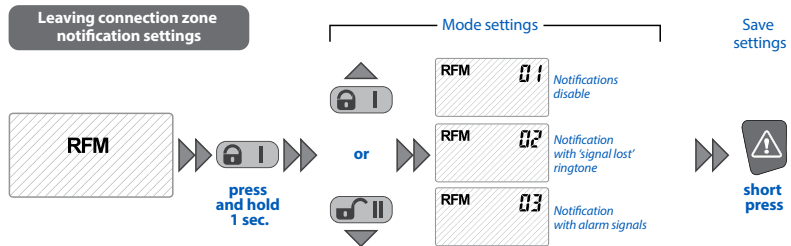

Factory setting for leaving connection zone notifications – disabled.

Siren signal settings

To configure siren sounds, enter the settings menu, select icon by pressing (F III) button. Select one of three siren sound options using or (A I).

To exit this mode and save, shortly press button, to exit without saving, press and hold (F III) button for 1 second or it will end automatically in 10 seconds.

- All sound signals are enabled
- Warning notifications are disabled
- All sound signals are disabled



Silent mode of the remote

This function disables all sound signals of the remote, this mode does not apply to alarm clock and main zones triggering. LED indication and vibration remain enabled.

To set silent mode of the remote, select icon by pressing (F III) button.

This function can be set using (A I) button (all sound signals are disabled) and button (all sound signals are enabled).

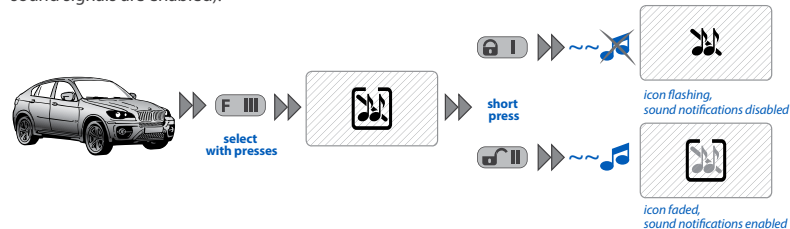









Time and alarm clock settings

Time settings

The system synchronizes time and date automatically.

NOTE: If it is required, time and date can be set by using a phone (see 'Changing core settings via phone' section). Before manual adjusting, the synchronization function of time and date in AlarmStudio should be disabled!

Alarm clock settings

To set up the alarm clock, select  icon with  button presses.  or  will be displayed on the numeric indicator. With short presses of  and  set alarm clock mode:  (enabled) or  (disabled). To proceed to setting alarm clock time, shortly press  button.

Checking the number of recorded remotes

Number of recorded remotes can be checked every time the ignition is switched on when disarmed. Number of orange LED flashes will indicate the number of recorded remotes.

Number of recorded remotes can also be checked by taking off and putting back on battery terminal. The system will sound the siren several times, equal to the number of recorded remotes.

Replacing a battery in the remote



If high quality batteries are used, service-security system remote can function up to 4 months without needing a replacement. Battery needs to be replaced, if the remote is not turning on or the  icon has only one bar left and starts flashing.

To replace the battery:

- move battery cover lock in the direction shown with arrow;
- take the battery out and place a new one on its place;
- the remote is ready for use (switch it on by pressing and holding  for 3 seconds).

It is recommended to keep an extra AAA battery in the car.

Arming/disarming using radio tag button

To arm/disarm the system, RF tag should be in radio coverage area (within a radius of 5 meters from the car). The system produces a protected (AES-128 encryption) interactive high-speed exchange of authorization codes in the frequency range 2,4 GHz on one of 125 channels. To arm the system when the ignition is switched off, shortly press the tag button. The system will confirm the command receiving with 1 short sound signal and 1 flash of turn indicators. To disarm the system, shortly press the tag button. The system will confirm the command receiving with 2 short sound signals and 2 flashes of turn indicators. Each button press will be confirmed with LED indicator flash of the tag that indicates the battery is functioning correctly. If LED indicator does not flash or light, the tag battery should be replaced (see 'Replacing immobilizer tag battery' section).



Arming/disarming in Hands Free mode

The system allows for programmable **Hands Free** arming and disarming. To arm the system, when the engine is not running, move with the remote tag away from the car at a distance greater than the regular radio coverage (10 meters for 2,4 GHz) – the system will be armed automatically. To disarm the system, move toward the car with remote tag. Enabling/disabling this function can be performed with a phone (see 'Control over system via phone' section).

Arming/disarming in slave mode

In this mode it is possible to monitor the status of original security system of the car via CAN-bus or by analog inputs. When arming and disarming original security system, Pandora will be armed and disarmed respectively. The presence of a tag in the radio zone is not required, but at the beginning of motion if the tag is not detected by the system, the engine will be blocked.

There is an option in the system settings named 'Disable disarming when the tag is not present'. When this option is enabled, disarming procedure will be performed only if there is a tag in the radio zone (it does not apply to the command **0***).

Pandora DXL-3050L is innovative and highly effective security solution that helps to prevent aggressive seizure of the car (hijacking) with the use of an immobilizer tag. To strengthen the defenses of the car, additional blocking relays can be installed (up to 3).

Immobilizer mode

This mode is enabled by default, use a phone to disable this mode (see 'Control over system via phone' section). When engine is running, base unit of Pandora security system performs a search for immobilizer tags in radio zone. If no tags were detected, LCD remote will play '**NO TAG FOUND**' ringtone. If no radio tags were detected when the ignition is switched on, the system will block the engine with all radio relays that were programmed into the system. Engine blocking will only occur when motion sensor detects movement of the car. If additional analogue blocking relays were installed, they will block the engine immediately, before or when the car starts moving, it depends on system settings.

Antihijack mode

This mode is disabled by default, use a phone to enable this mode (see 'Change settings via phone' section). **Antihijack mode** helps to prevent aggressive seizure of the car using delayed engine blocking on door opening.

Every time when the engine is running on opening/closing a door, immobilizer requests response from a remote using unique algorithm. After a door was opened while the engine is running, if the system cannot detect a radio tag, the engine will be stopped after 1 minute (general safety requirement). Before blocking '**ENGINE BLOCKING WARNING**' ringtone will play.

If engine blocking is performed via radio relay after warning signals are over or on new attempts to start the engine, immobilizer will only allow the engine to start when the car is not moving, and will block it again if it starts movement. Immobilizer will be in active mode in no more than 2 seconds after the ignition is switched on. If the car starts moving, the immobilizer will block the engine for 15 seconds. When registered tag appears in the radio zone, blocking will be canceled and the system will return to the normal operation.

If the engine is blocked via analog relay, engine operation will be stopped after warning signals will be over, and until a registered tag appears in the radio zone or on registering movement – depending on the settings.



WARNING!
IF THE TAG IS IN RANGE BUT THE ENGINE KEEPS BLOCKING, CHECK RADIO TAG BATTERY!

Immobilizer code using original car controls

Code immobilizer is a function that allows disarming and controlling timer channels using original car controls (button, lever or pedal). To enter immobilizer code, programmed button (lever, pedal) should be pressed a number of times equal the digit of the code. Pauses between presses should not exceed 1 second. Pauses more than 1 second will be interpreted as the start of next digit input. Immobilizer code can consist max of 4 digits from 1 to 9.

After entering a correct immobilizer code, depending on the settings, either the engine blocking will be lifted or a programmed timer channel will be activated.

Replacing immobilizer tag battery

Carefully open the cover of the tag's battery compartment. Extract discharged battery and insert a new one keeping in mind the correct polarity. Replacing a battery will not cause a loss of tag code information, as authorization data is stored in the non-volatile memory of the MCU.

Carefully close the cover of the tag's battery compartment. All elements of construction should be rigidly locked in places. If it is so, the tag can be operated as usually.

Control over system in case of emergency

Use a phone to deactivate the system quickly. To disarm the system via a phone, call the system's number. When it answers, dial command **0***. If the call is not made from the owner's number, guest PIN-code should be entered. Factory set guest PIN-code is **1-2-3-4**. To switch off immobilizer RF tag/Antihijack mode, dial command **998*** (after dialing, enter individual PIN-code that is located on the owner's plastic card).

If the system cannot be deactivated via a phone, apply emergency disarming/switching off immobilizer RF tag using VALET button.

Emergency disarming/switching off immobilizer using VALET button

In case you cannot disarm the system using a remote, phone or online service, owner's individual PIN-code can be used. Individual PIN-code is written on the owner's plastic card under protective layer. Erase the protective layer and use VALET button to input PIN-code.



WARNING!
MAKE SURE THAT PROTECTIVE LAYER ON THE OWNER'S PLASTIC CARD IS INTACT AFTER THE INSTALLATION OF THE SYSTEM. PLASTIC CARD HOLDS INDIVIDUAL PIN-CODE AND ONLINE SERVICE ACCESS INFORMATION.

Erase the protective layer and use VALET button to input PIN-code.

1. Using VALET button, input the first digit of the code (press the button a number of times, equal to the first digit; pauses between presses should not exceed 1 second). The system will confirm with red LED indicator flash.

2. Similarly input second, third and fourth digit. Every input will be confirmed with red LED flash.

3. The system will confirm correct PIN-code with red and green flashes of LED indicator. If the input was incorrect, it will be indicated with long red flash. New input can be attempted after 5 seconds.

If immobilizer/Antihijack mode is activated:

4. Using VALET button, input PIN-code. Factory preset PIN-code is 1-1-1-1 (4 presses with pause for 2 seconds).

5. The system will confirm correct PIN-code with red and green flashes of LED indicator and will enter programming mode. New input can be attempted after 5 seconds.

6. To switch off immobilizer/Antihijack function, press VALET service button 15 times (pauses between presses should not exceed 1 second). The LED will be lit green.

7. Input individual PIN-code similar to emergency disarm. The system will confirm correct PIN-code with 2 short signals of the siren and with red flash of LED.

8. To activate immobilizer/Antihijack function, enter level 15, the system will confirm it with red flash of LED. Press VALET button once, the system will confirm it with green flash of LED and with 1 short signal of the siren. For emergency arming when the engine is stopped, press and hold VALET button for 3 seconds. The system will be armed in 30 seconds.

While there is a countdown, the LED will be lit red.

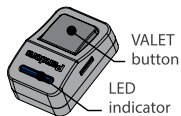

Pandora

RMD-8

(available optionally)

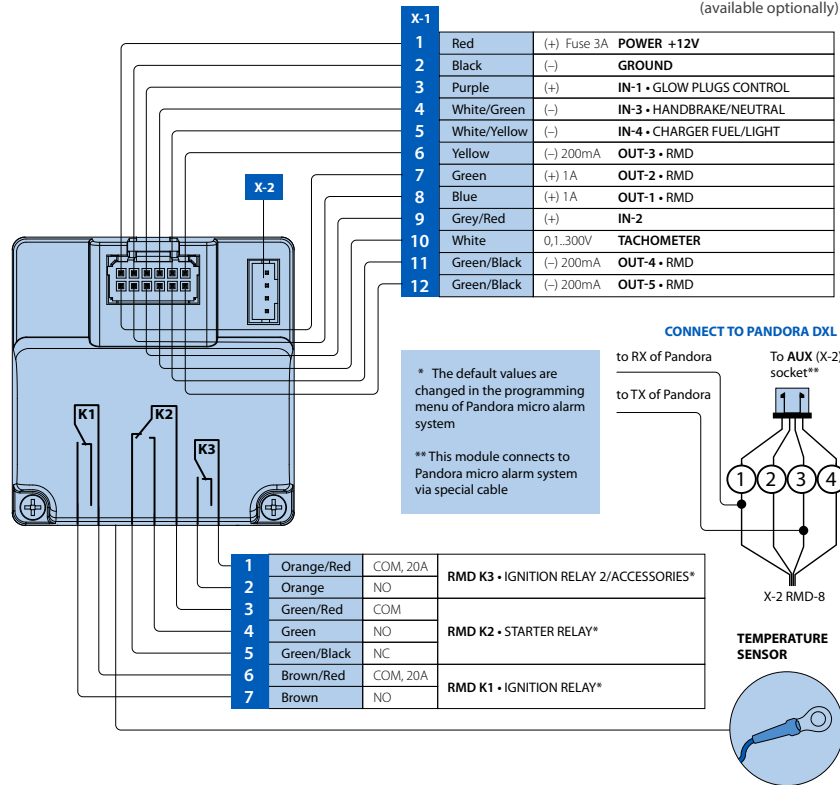

WARNING!!!
Do not accidentally shield the antenna!

WARNING!!!
For proper installation a connected laptop with AlarmStudio software is required. Switch the system to programming mode (see page 37) and select your car model in AlarmStudio for detailed installation instructions. AlarmStudio can be downloaded from pandorainfo.com

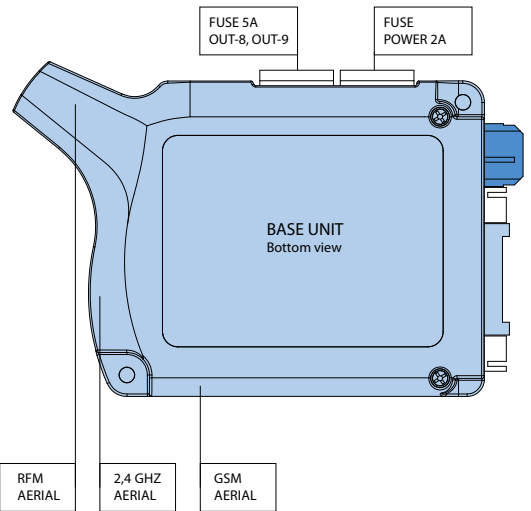

X-1 Power socket

1	Red	(+)	POWER +12V
2	Black	(-)	GROUND
3	Grey/Red	(+) 2A	OUT-8 • TO TURN LIGHTS, RIGHT SIDE
4	Grey/Black	(+) 2A	OUT-9 • TO TURN LIGHTS, LEFT SIDE

When it is connecting, change logic operation to direct and potential

X-2 Microphone socket

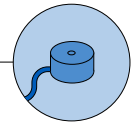

MICROPHONE

X-3 Main socket

1	White		DATA TX • TO ADDITIONAL DEVICES
2	Red/Black	(-) 200mA	OUT-6 • BEEPER
3	Orange/White		CAN1-HIGH
4	Yellow/White	200mA	CAN2-HIGH / OUT-2 • OPENING CENTRAL LOCK
5	Grey	(-) 200mA	OUT-1/INP-1/IMO • DOOR SWITCHES
6	Green	(-) 200mA	OUT-4/INP-4/IMI • TO TURN LIGHTS
7	Blue/White	(+)	INP-5 • BRAKE PEDAL BUTTON
8	Black		LIN IN
9	Blue		DATA RX • TO ADDITIONAL DEVICES
10	Brown/White	(-) 200mA	OUT-7/INP-3 • FRONT HOOD/TRUNK SWITCHES
11	Orange/Black		CAN1-LOW
12	Yellow/Black	200mA	CAN2-LOW/OUT-5 • CLOSING CENTRAL LOCK
13	Blue/Black	(-) 200mA	OUT-3 • ENGINE BLOCK
14	Yellow	(+)	INP-2 • IGNITION SWITCH
15	Purple	(+) 2A	OUT-10 • SIREN
16	Green/Orange		LIN OUT

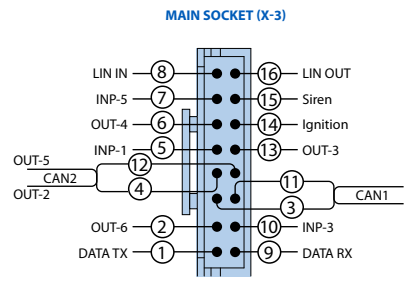

X-4 VALET button

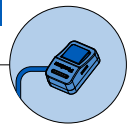

VALET LED BUTTON | INDICATOR

BLOCKING RELAY

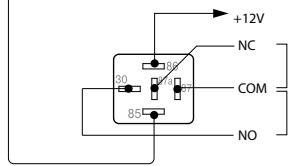

(available optionally)

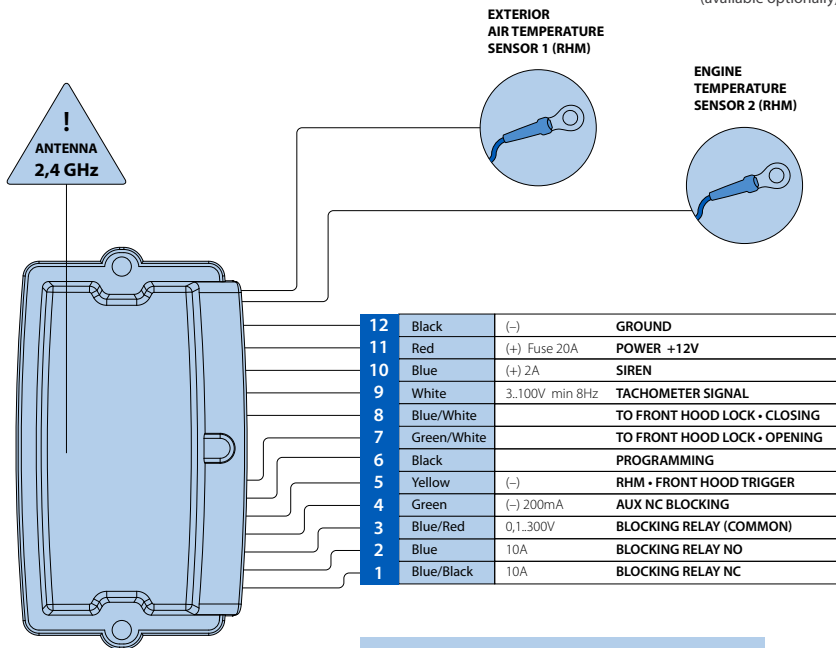

WARNING!!!

Place radio module unit wires down.
Do not shield zone of built-in aerial (no less than 3 centimeters from metal surfaces).

INSTALLATION AND CONFIGURATION OF THE SYSTEM

Wiring description

X-3 socket (main)

Wire 1 (White) (DATA TX) It connects to appropriate additional devices wires (optional).

Wire 2 (Red-black) (OUT-6) (Beeper) A negative output of additional channel with maximum load capacity 200mA. This output is multipurpose, it can operate in accordance with selected logic.

Wire 3 (Orange-white) ('CAN1-High') It connects to appropriate CAN-High wire of the car.

Wire 4 (Yellow-white) ('CAN2-High'/OUT-2) Factory setting is 'Open central lock'. A negative impulse of 0,8 second is formed on the wire to open central lock. Logic of the channel's operation can be set in the table of system outputs in AlarmStudio. Channel OUT-2 stops operating as an output when a car code with enabled digital CAN2-bus is chosen.

Wire 5 (Grey) (INP-1/OUT-1/IMO) Factory setting is 'Door switches'. This wire connects to a wire that becomes grounded when the door opens. This input is multipurpose, it can operate in accordance with selected logic. The channel can be programmed as IMO input, for keyless bypass of the immobilizer (connects according to the installation diagram).

Wire 6 (Green) (INP-4/OUT-4/IMI) Factory setting is 'Control turn indicators'. This wire connects to the hazard flashers button. This channel is multipurpose, it can operate in accordance with selected logic. The channel can be programmed as IMI output, for keyless bypass of the immobilizer (connects according to the installation diagram).

Wire 7 (White-blue) (INP-5) Factory setting is 'Brake pedal limit switch'. This wire connects to the brake pedal button where 12V voltage appears when the pedal is pressed (stop lights wire). Brake pedal signal is one of the system's security zones. This input is multipurpose, it can operate in accordance with selected logic.

Wire 8 (Black) (LIN IN) It is special digital input. This wire is used for incut connection to LIN-bus in accordance with diagram.

Wire 9 (Blue) (DATA RX) It connects to appropriate additional devices wires (optional).

Wire 10 (Brown-white) (OUT-7/INP-3) Factory setting is 'Front hood limit switch'. This wire connects to appropriate wire that becomes grounded when the front hood opens. This input is multipurpose, it can operate in accordance with selected logic.

Wire 11 (Orange-black) ('CAN1-Low') It connects to appropriate CAN-Low wire of the car.

Wire 12 (Yellow-black) (OUT-2) Factory setting is 'Close central lock'. A negative impulse of 0,8 second is formed on the wire to close central lock. Logic of the channel's operation can be set in the table of system outputs in AlarmStudio. Channel OUT-5 stops operating as an output when a car code with enabled digital CAN2-bus is chosen.

Wire 13 (Blue-black) (OUT-3) Factory setting is 'Blocking'. This wire is used to control external analogue blocking relay with a normally open logic (it becomes grounded when switching on the ignition and security system is not armed and radio tags are in range).

Wire 14 (Yellow) (INP-6) Factory setting is 'Ignition'. This wire connects to ignition switch or to appropriate wire where 12V voltage appears when ignition is switched on and doesn't disappear until the moment ignition is switched off. This input is multipurpose, it can operate in accordance with selected logic.

Wire 15 (Purple) ('siren') It connects to siren control wire (+) (maximum load current is 2A). This channel is multipurpose, it can operate as input or output in accordance with selected logic.

Wire 16 (Green-red) (LIN OUT) It is special digital input/output. This wire is used to control preheaters and to operate in conjunction with LIN cars.

X-1 socket (additional)

Wire 1 (Red) ('Power supply' 12V) It should be connected to reliable conductor with constant voltage of 12V.

Wire 2 (Black) (ground) It should be connected to the car body in a grounding spot. This wire should be connected FIRST during installation.

Wire 3 (Grey-red) (OUT-8) (Control turn indicators) It is positive power output. This wire connects to the control turn indicators wire. Maximum load capacity is 2A. Settings of control turn indicators should be changed to 'potential' in the system settings. This output is multipurpose, it can operate in

accordance with selected logic.

Wire 4 (Grey-black) (OUT-9) (Control turn indicators) It is positive power output. This wire connects to the control turn indicators wire. Maximum load capacity is 2A. Settings of control turn indicators should be changed to 'potential' in the system settings. This output is multipurpose, it can operate in accordance with selected logic.

Programming system and entering PIN-code

The system settings can be changed via computer. The system should be connected to a computer via standard micro-USB cable and a special piece of software – **Pandora AlarmStudio**.

AlarmStudio can be downloaded from the official company web-site pandorainfo.com

Entering programming menu:

1. Disarm the system, switch off the ignition.
2. Connect the base unit of the system to a computer via micro-USB cable.
3. Using VALET button, input service PIN-code. Factory preset PIN-code is **1-1-1-1**.



WARNING!
IF YOU ARE AN INSTALLER, DO NOT ERASE PROTECTIVE LAYER OF THE OWNER'S PLASTIC CARD! IN CASE A CUSTOMER COMPLAINS ON ERASED PROTECTIVE LAYER OF THE CARD WITH THE INDIVIDUAL PIN-CODE, RE-INSTALLATION OF THE SYSTEM IS CARRIED OUT AT THE EXPENSE OF THE INSTALLER.

4. Using VALET button, input the first digit of the service code (press the button a number of times, equal to the first digit; pauses between presses should not exceed 1 second). The system will confirm entering of the first digit with red LED indicator flash.

5. Similarly input second, third and fourth digit. Every input will be confirmed with red LED flash.

6. The system will confirm correct PIN-code with red LED flashes and proceed to the programming mode. If the input was incorrect, it will be indicated with long red flash and the system will proceed to previous mode. New input can be attempted after 5 seconds.

Changing core settings via computer

The system allows programming all settings and updating software of the base unit via the interface micro-USB cable or via radio channel using a computer. It does not matter, whether base unit is installed into a vehicle or not. Software reads the current setting and allows changing them. If base unit has not yet been installed in the vehicle, it should be powered via micro-USB cable while programming. To program using a computer connected via cable, you need a standard micro-USB cable, a computer with Windows and a special piece of software – Pandora AlarmStudio.

In preparation to the programming following stages should be followed:

- connect micro-USB cable to any free USB socket of the computer;
- start Pandora AlarmStudio (can be downloaded from the web-site);
- enter the programming settings mode by entering the service PIN-code on the base unit using VALET button. Factory preset PIN-code is 1-1-1-1.

If the software configuration is carried out via the radio interface of 2,4 GHz, special USB programmer RMP-03 should be used.

Configuring system settings via the wireless interface 2,4 GHz

To change the configuration of the system using a wireless interface 2,4 GHz, enter programming level 10. The system will await a wireless connection from the computer for 2 minutes.

Entering the programming menu using VALET button

Level 1	Recording remotes and radio tags into the system's memory
Level 2	Changing the factory preset service PIN-code
Level 3	Recording the idle speed to the system's memory
Level 4	Resetting to factory settings
Level 5	Programming RHM engine compartment module
Level 6, 7	Programming radio relays 1 and 2
Level 8	Recording GPS/GLONASS receiver Pandora NAV-035
Level 9	Recording of Pandora RW smart watch
Level 10	Configuring system settings via the wireless interface 2,4 GHz
Level 11	Programming validator code of immobilizer (Pin to Drive)
Level 12	Setting and updating GPS/GLONASS receiver NAV-035
Level 13, 14	Reserved
Level 15	Emergency disabling of immobilizer
Level 16	Reserved
Level 17	Setting up keyless bypass of built-in immobilizer

Changing core settings using VALET button

Level 1 Recording remotes into the system's memory

Enter the first level of programming. Remotes are recorded (paired) one by one. The pause between recording of remotes and radio tags should not exceed 20 seconds.

To pair the radio tag, press button on the tag and hold it for 3 seconds. If the recording was successful, the base unit will emit 1 beep, after that you can move to recording the next tag.

To pair the remote, press three buttons simultaneously (on the remote) and hold them for 1 second (until a short beep for the LCD remote), then release the buttons.

To finish the recording of the remote units into the system, VALET button should be pressed again, the status LED will produce series of red flashes; then switch on and off the ignition to leave the programming mode.



WARNING!
IF THE CONTROL OVER SIREN IS CARRIED OUT USING RHM ENGINE COMPARTMENT MODULE, SIREN SOUND SIGNALS WILL NOT BE EMITTED DURING RADIO TAGS RECORDING!

Level 2 Changing the factory preset service PIN-code

• Indicator LED is not lit. Press VALET button the number of times equal to the first digit of the new security code. Each pressing of VALET button is followed by red flash of the indicator. The interval between the presses should not exceed 1 second.

- The input will be confirmed with red flash of indicator.
- Enter the other numbers in the same manner.
- The input of the fourth number will be confirmed by series of red and green LED indicator flashes.
- Enter all four numbers again.
- If you were able to correctly enter code twice, the indicator will produce series of red flashes and a new PIN-code will be recorded, the system will return to the programming mode.
- In case of the incorrect code input the indicator will be lit red and the system will return to the programming mode.

After the input is complete, the indicator fades, the system awaits a new programming level input.

Level 3 Recording the idle speed to the system's memory

At this programming level the idle turns speed of the engine is recorded (into non-volatile memory). Upon entering this level you need to switch the ignition on and start the engine (it should be warmed-up and the idle speed should match a normal rate for the heated engine). Wait until the stable idle speed is reached (it takes about 30 seconds). Then press VALET button once. The ignition should be switched off after recording. While on this programming level, you can start and stop the engine many times – it will only be exited on VALET button press.

Level 4 Resetting to factory settings

To reset to the factory settings, you need to enter programming level 4, then press and hold VALET button for 5 seconds until siren sound signal. Once VALET button is released, the status indicator will confirm a successful reset to factory settings with a long red flash.

Level 5 Programming of RHM engine compartment module

1. Enter programming mode on level 5.
2. Perform programming according to the instructions to the device (see on page 46).

Level 6, 7 Programming of radio relays 1 and 2

1. Select the desired level of the programming menu 6 or 7 for programming radio relays 1 or 2 respectively.
2. Connect the wire 3 of the radio relay to a grounded spot.
3. Apply power (+12V) on the contacts 2 and 4 of the radio relay. Siren will confirm radio relay recording to the memory on level 6 with 2 beeps. Siren will confirm radio relay recording to the memory on level 7 with 3 beeps.
4. After a successful radio relay recording, contact 2 should be disconnected and insulated, contact 4 should be connected to the constant power supply 12V or to the wire where there is a constant 12V when ignition is switched on.

Level 8 Recording GPS/GLONASS receiver Pandora NAV-035

Enter this level and connect power to the GPS/GLONASS receiver Pandora NAV-035. Siren of the base unit will confirm successful recording with 1 beep.

Level 9 Recording of Pandora RW smart watches

Watches are recorded (paired) one by one. To pair the watches, press three functional buttons simultaneously (on the watches) and hold them for 1 second (until a short beep), then release the buttons. If the recording was successful, the base unit will emit 1 beep, after that you can move to recording the next device. The pause between recordings of watches should not exceed 20 seconds.



WARNING!
IF THE CONTROL OVER SIREN IS CARRIED OUT USING ENGINE COMPARTMENT MODULE RHM, SIREN SOUND SIGNALS WILL NOT BE EMITTED DURING WATCHES RECORDING!

To finish recording watches into the system, VALET button should be pressed again, the status LED will produce series of red and green flashes; then switch on and off the ignition to leave the programming mode.

Level 10 Configuring system settings via the wireless interface 2,4 GHz

To change the configuration of the system using a wireless interface 2,4 GHz, enter programming level 10, the system will confirm the entering with red flash of LED indicator. The system will await a wireless connection from the computer for 2 minutes. If the waiting time limit has expired and the system was not connected to the computer, it will exit this level.

Level 11 Programming validator code of immobilizer (Pin to Drive)

1. Select the button to set the secret validator code of immobilizer.

To do this, enter level 11 of programming and press the selected button (e.g. wheel 'volume up' button), LED indicator will confirm input with orange flashes. If there are no orange flashes when any button is pressed, then this button is not recognized by the system, select a different button. After the button was chosen, press VALET button. Security system will memorize the last pressed button (which was pressed before VALET button) as a button to enter PIN-code of immobilizer and will await input of the first digit of PIN-code.

2. Program the immobilizer deactivation PIN-code.

Enter the first digit by pressing the previously selected button (pause between pressing must be no more than 1 second). The base unit will confirm entering with red flash of LED indicator.

Input the second (third, fourth) digit by pressing the previously selected button. The base unit will confirm entering with red flash of LED indicator.

Input the required number of digits (up to 4) and then press VALET button. The system will confirm receiving of the secret validator code with long red flash of LED indicator and will expect for confirmation of PIN-code.

3. Confirm the immobilizer deactivation PIN-code.

Input PIN-code again similarly to the programming procedure and press VALET button. The system will confirm correct PIN-code with red and green flashes of LED indicator and will memorize PIN-code, then will proceed to the programming mode awaiting level input. Incorrect confirmation is indicated with long red flash of LED indicator, after that the system will return to a programming mode.

Level 12 Setting and updating GPS/GLONASS receiver NAV-035

To update the firmware of NAV-035 via the 2,4 GHz wireless interface, run the GPS Loader software and enter the programming level 12. After entering, update software of GPS/GLONASS receiver.

Level 15 Emergency disabling of immobilizer

To deactivate the immobilizer/Antihijack function, enter the programming level 15, the system will confirm the entering with green flash of LED indicator. Input the first digit of the secret code using VALET button (press the button a number of times, equal to the first digit; pauses between presses should not exceed 1 second). The system will confirm input with red flash of LED indicator. Enter the other three digits in the same manner. The correct input will be confirmed with 2 short sound signals of the siren and with red flash of LED indicator. To activate immobilizer/Antihijack function, enter level 15, LED will confirm input with red flash. Press VALET button once, siren will emit 1 short beep.

Level 17 Setting up keyless bypass of built-in immobilizer

This level enters programming mode to teach algorithmic keyless bypass of built-in immobilizer. LED indicator will be lit green when on this level. If system installation was performed correctly on successful engine start using a key, LED indicator will flash green and siren will emit a short signal. To save and finish, press VALET button. Now the system should be able to simulate key for remote starts. For more in-depth instructions, use AlarmStudio.

Additional devices

Expansion module RMD-8 (see diagram on page 31)

Expansion module RMD-8 is designed to be used in conjunction with Pandora DXL-3050L, 1700L and 5000L service-security systems. RMD-8 allows to significantly expand the capabilities of a system, provides the ability to connect to the vehicle power circuits (up to 20A) and adds 8 additional programmable outputs (OUT) and 4 analogue inputs.

RMD-8 is mainly needed to allow remote engine start function via analogue connection when it is not possible to remotely start engine via CAN-bus.

Module provides control over basic parameters needed for correct and safe operation of the engine: temperature and engine speed, glow plugs control, state of oil lamp/charge and handbrake/neutral.

All the necessary information for the software updates can be downloaded from the official company web-site pandorainfo.com

Name of parameter	Value
Current consumption	no more than 7mA
Supply voltage	9-15V
Operating temperature range	from -40 to +85°C
The maximum load current, dial-out	
RMD OUT-1 (+)	1A
RMD OUT-2 (+)	1A
RMD OUT-3 (-)	200mA
RMD OUT-4 (-)	200mA
RMD OUT-5 (-)	200mA
RMD K1	20A
RMD K2	20A
RMD K3	20A
Permissible amplitude of tachometer signal	3-300V
Dimensions	45,5x44x17 mm

Blocking radio relay

For Pandora DXL-3050L optionally blocking RR-102 radio relay is available. Blocking radio relay with built-in accelerometer should be placed in the engine compartment. Herewith zone of built-in aerial 2,4 GHz should not be shielded.

Provide a rigid fastening to the car body or to the fixed wirings. It is forbidden to hide the module in wiring. Radio relay power connects either from ignition or from a constant power wire. Radio relay is normally closed, blocking is carried out only on unauthorized movement.

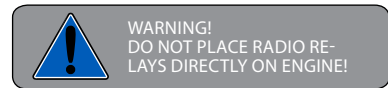
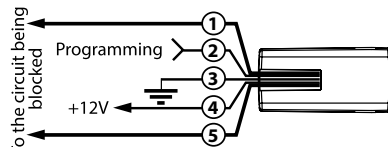

RR-102 Radio relay connection

Wire 1 and 5 (Black) – Blocking.

These wires should be connected to the circuit in need of blocking. Switching current must be no more than 10A (for switching circuits without inductive load component). The relay contacts are normally closed.

Wire 2 (Black) – Programming.

This wire is used to record radio relay to the system's memory. When recording, the wire connects to 12V simultaneously with wire 4.

Wire 3 (Black) – Ground.

This wire should be connected to the car body in a grounding spot or to a reliable conductor, connected to car body or to any grounded device. The wire should be connected FIRST during installation.

Wire 4 (Black) – Power supply 12V.

This wire should be connected to reliable conductor with constant voltage of 12V or to any wire, which has constant voltage of 12V when engine is running and this voltage does not disappear when driving.

Programming of radio relay

Radio relay can be programmed on level 6 and 7. Level 5 is used to program engine compartment module RHM.

1. Select desired level of the programming menu 6, 7 to program radio relay 1, 2 respectively.
2. Connect wire 3 of radio relay to the grounding spot.
3. Apply power (12V) to the contacts 2 and 4 of radio relay. The siren will confirm recording of radio relay to the system's memory on level 6 with 2 beeps and on level 7 with 3 beeps.
4. After successful recording of radio relay switch off and insulate contact 2, connect contact 4 to the constant power 12V or to any wire, which has constant voltage of 12V when engine is running.

Radio module of engine compartment RHM-06 (see diagram on page 34)

This module is designed to simplify the system installation and wiring in the engine compartment, it allows to control additional devices (siren, tachometer, engine blocking, motion sensor and etc.) via 2,4 GHz radio channel.

Engine compartment module RHM-06 is installed discreetly in the engine compartment on the vehicles with 12V on-board voltage.



WARNING!
DO NOT INSTALL THE MODULE NEAR THE EXHAUST MANIFOLD, AS WELL AS IN PLACES WITH HIGH HUMIDITY!

When installing the device, avoid shielding of built-in aerial 2,4 GHz by metal parts of the car body.

Wire 1 (Blue-black) is N.C. relay contact, this wire connects to the blocking engine circuit.

Wire 2 (Blue) is N.O. relay contact, this wire is used for blocking with bypass grafting.

Wire 3 (Blue-red) is general relay contact, this wire connects to the blocking engine circuit.

Wire 4 (Green) is output to control additional blocking relay with N.C. contacts. Blocking operates in accordance with logic of built-in blocking relay.

Wire 5 (Yellow) is input of front hood limit switch. RHM input (front hood trigger) can operate

in accordance with selected logic in the 'input table' of the system (control of glow plugs, generator charge lamp and etc.).

Wire 6 (Black) is the programming wire, this wire is used when recording module to the system's memory.

Wire 7 (Green-white) and **8** (Blue-white) are outputs to control front hood lock. These wires connect to devices with current consumption no more than 15A. Front hood lock will be open if three conditions are satisfied:

- the system is disarmed,
- engine is running,
- radio tag is in range of the system base unit.

Front hood lock will be closed if any of the following conditions have occurred:

- radio tag is 'lost',
- the system is armed,
- engine is stopped (blocking is performed with delay of 15 seconds),
- when blocking command **666*** is issued via a phone.

To set different hood lock logic, program a setting in the 'Block of timer channels 10(K)' section. When closing the lock, the status of the hood trigger is taken into account (by analog or CAN), if the hood is open, closing the lock is performed after hood is closed with a delay of 3 seconds. If the system is in maintenance/valet mode, the hood lock is always open.

Wire 9 (White) is analog tachometer input, this wire should be connected to a wire of tachometer or signal wire of injector, a wire with stable impulses of any polarity that correspond with motor shaft rotation frequency.

Wire 10 (Blue) is a siren, this wire connects to siren control wire (+) (maximum load current is 2A).

Wire 11 (Red) is power supply 12V, this wire connects to any wire that has constant voltage of 12V. The circuit should be protected by a fuse (20A). If this condition is not satisfied, device can be damaged and it can impact the security features of the system.

Wire 12 (Black) is ground, this wire should be connected to the car body in a grounding spot or to a reliable conductor, connecting car body or to any grounded device. The wire should be connected **FIRST** during installation.

Programming mode (recording) of RHM-06 module

1. Enter the programming mode on the level 5.
2. Wire 6 (programming) of RHM-06 module connects to wire 12 (ground) and connects with a grounded spot of the car.
3. After wire 11 is connected (module power 12V), the system will confirm recording of the module to the system's memory with 1 beep of the siren connected to the base unit. If the siren is connected to the RHM-06 module, there will be no sound signal.
4. Disconnect the programming wire 6 from wire 12 and insulate the wires.

GPS/GLONASS receiver NAV-035

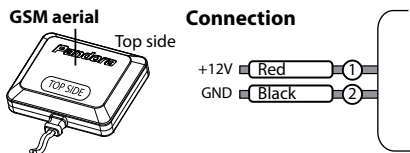

Pandora NAV-035 is a high sensitivity GPS/GLONASS receiver used to determine precise coordinates of the car. The receiver operates on our 2,4 GHz wireless interface. The receiver should be placed under the dashboard, aerial should be placed in the top for better reception of the satellite signal.

Programming of GPS/GLONASS receiver NAV-035

Enter level 8 of programming mode using VALET button and apply power to GPS/GLONASS receiver Pandora NAV-035. If the recording was successful, siren of the base unit will emit a confirmation beep.

CONTROL OVER SYSTEM VIA PHONE

Call the system's phone number. When it answers, enter command code.



WARNING!
IF THE CALL IS NOT MADE FROM THE OWNER'S NUMBER, GUEST PIN-CODE SHOULD BE ENTERED. FACTORY SET GUEST PIN-CODE IS 1-2-3-4. AFTER THE SYSTEM IS INSTALLED, PLEASE CHANGE FACTORY SET PIN-CODE.

#	Return to previous menu/state	6 6 6 *	Enable engine blocking
*	Repeat the last message	9 9 9 *	Disable engine blocking
1 *	Arming	2 5 8 *	System information
0 *	Disarming	9 9 8 *	Disable immobilizer and Antihijack
1 0 *	Silent arming	8 8 8 *	Enable immobilizer and Antihijack
0 0 *	Silent disarming	2 2 2 *	Disable Hands Free mode
9 *	Help	2 2 3 *	Enable Hands Free arming
0 9 *	Event history	2 2 4 *	Enable Hands Free disarming
0 0 7 *	Switch on interior microphone	2 2 5 *	Enable Hands Free disarming only with autom. start
1 0 0 *	Request GSM account balance	7 8 9 *	Enable automatic engine start
1 2 3 *	Start the engine/prolong heating	9 8 7 *	Disable automatic engine start
3 2 1 *	Stop the engine	2 9 7 *	Call ended
3 3 3 *	Switch on additional function using F button via CAN	5 5 1 *	Enable maintenance/valet mode (see description below)
5 0 0 *	Request current coordinates	5 5 2 *	Disable maintenance/valet mode
4 5 6 *	Switch on additional channel	1 5 6 *	Switch on preheater
6 5 4 *	Switch off additional channel	6 5 1 *	Switch off preheater

Control via speed dial DTMF commands

For example: To have simple access to engine start function, create a new contact in the contact list of your phone, name it 'Engine start', for instance, and add the number in the following format: +XXXXXXXXXXXX,123*,297*, where:

'+XXXXXXXXXXXX' – the system's phone number,
'/' – pause is a feature of the phone (can be displayed as the 'P', see the instructions of the phone),
'123*' – remote engine start DTMF command,
'297*' – end call DTMF command.

Contact can be added as a speed dial to any of the free button.

To have simple access to engine start function a phone other than the main owner's phone, create contact in the following format: +XXXXXXXXXXXX,1234,123*,297*, where:

'1234' – guest PIN-code.

Enable/Disable maintenance/valet mode

1. Call system's number. Wait for answer.
2. To enable maintenance/valet mode, dial 'Enable maintenance/valet mode' DTMF command **551*** (engine must be running, radio tag on the 2,4 GHz should be in range if immobilizer/Antihijack mode is active).
3. Enter individual PIN-code that is located on the owner's plastic card.
4. To disable maintenance/valet mode, dial **552*** DTMF command.

Voice help

The system has voice help menu. During voice call to the system, dial **9*** and listen to the information about system control commands. To end session, hang up the phone.

Repeat the last message

To repeat any message, press * during a voice call to the system.

Arming/disarming

1. Call the system's number. Wait for answer.
2. Dial **1*** to arm or **0*** to disarm.
For silent arming dial **10*** or **00*** for silent disarming.
3. The system will confirm: 'Arming/Disarming'.
To end session, hang up the phone.

Similarly any other system commands can be entered.

Enabling/disabling automatic engine start

Pandora system has function of promptly disabling automatic engine start.

1. Call the system's number. Wait for answer.
2. Dial **987*** to disable all automatic engine starts or **789*** to enable all automatic engine starts.
3. The system will confirm execution.

To end session, hang up the phone.
Automatics starts can be enabled again either by dialing **789*** (all previous settings will remain intact).

Locking/unlocking the engine

You can block car's engine using any phone. The engine will remain blocked until phone command 'Unlock engine' will be sent. This blocking cannot be disabled using a remote.

1. Call the system's number and wait for answer.
2. Dial **666*** to enable engine blocking or **999*** to disable engine blocking (after dialing, you will need to enter individual PIN-code that is located on the owner's plastic card).

Request current coordinates

1. Call the system's number. Wait for answer.
2. Dial **500***.
3. The system will confirm: 'Current coordinate sent via text message' and will send text message with coordinates and a web link to a map to your phone.

To end session, hang up the phone.

Switching on interior microphone

1. Call the system's number. Wait for answer.
2. Dial **007***.
3. The system will switch interior microphone on.

To end session, hang up the phone.

Request GSM account balance

1. Call the system's number. Wait for answer.
2. Dial **100***.
3. The system will confirm: 'Balance information sent via text message' and will send text message with account balance information to your phone.

To end session, hang up the phone.

Changing core settings via phone

To enter settings programming mode:

Option 1. Disarm, call the system's number, wait for answer, then press and hold  button on LCD remote for 3 seconds. The system will switch into settings programming mode.

Option 2. Disarm, call the system's number, wait for answer, switch ignition on for 1 – 3 seconds then off. The system will switch into settings programming mode.



WARNING!
THERE ARE ONLY TWO WAYS TO CHANGE THE OWNER'S PHONE NUMBER:
1. VIA PHONE, USING CORE SETTINGS MENU;
2. VIA COMPUTER AND PANDORA ALARMSTUDIO SOFTWARE.

Example of changing the owner's system number:

1. Enter the setting menu via phone according to the instructions above;
2. Dial DTMF command **1*** (phone number settings) and **1*** (owner's system number);
3. Enter new owner's number in the format ***XXXXXXXXXX#** (the system recognizes '*' as '+');
4. To confirm, dial **1***.

1 * Phone number settings	1 *	Owner's number -> #
	2 *	Additional owner's number -> #
	3 *	Second additional owner's number -> #
	4 *	Account balance inquiry number -> #
2 * Settings of the voice calls	1 *	Voice calls on alarm
	2 *	Voice calls on triggering warning level of the sensors
	3 *	Voice calls on engine start
	4 *	Voice calls on engine stop
	5 *	Voice calls on restoring GSM connection
	6 *	Voice calls on disarming
	7 *	Voice calls on entering programming mode
	8 *	Voice calls when radio relay connection is lost
	9 *	Voice calls when on-board voltage is low
3 * Settings of the text messages	1 0 *	Voice calls on accident
	1 *	Text messages on alarm
	2 *	Text messages on triggering warning level of the sensors
	3 *	Text messages on engine start
	4 *	Text messages on engine stop
	5 *	Text messages on restoring GSM connection
	6 *	Text messages on disarming
	7 *	Text messages on entering programming mode
	8 *	Text messages when radio relay connection is lost
	9 *	Text messages when on-board voltage is low
4 * Immobilizer settings	1 *	Immobilizer (on/off)
	2 *	Anthijack
5 * Additional settings	1 *	Changing guest PIN-code
	2 *	Entering as guest
	3 *	Remote blocking
	4 *	Switch on interior microphone
6 * Automatic engine start settings	5 *	Set threshold voltage for sending text message
	1 *	By time
	2 *	Set up time for automatic start
	3 *	By voltage
	4 *	Set up voltage for automatic start
7 * Sensor sensitivity settings	5 *	By temperature
	6 *	Set up temperature for automatic start
	7 *	By period
	8 *	Set up period for automatic start
	1 *	Settings of the warning level of the shock sensor sensitivity
	2 *	Settings of the alarm level of the shock sensor sensitivity
	3 *	Settings of the motion sensor sensitivity
	4 *	Settings of the warning level of the supplementary sensor sensitivity
5 *	Settings of the alarm level of the supplementary sensor sensitivity	
8 * Settings of saving mode	1 *	GSM connection
	2 *	Money saving mode of the GSM connection
	3 *	Voice calls in roaming service
9 * Current time and date settings	1 *	Set up date
	2 *	Set up time

Pandora online information service pro.p-on.ru and mobile apps

Registration

Visit pro.p-on.ru website and register, following the instructions.

System login

After completing of the registration process, you can login to online service via computer's web browser or via special mobile apps for the Android (Pandora Online) and iOS (Pandora Pro). Only the main functions are available in these apps with DXL-3050L.

Mobile apps

These apps are free and available through your device's app store (AppStore, Google Play). To access the app, use the login data received from the service at the registration stage.

Adding a car to the online service

Internet service pro.p-on.ru can support simultaneously several telemetry systems, installed on various cars (private car park).

To add a telemetry system (car) to the service, press 'Add car' button and go through the process of adding, following the instructions.

To add a car, individual owner's card with registration information is needed (shipped with the system).

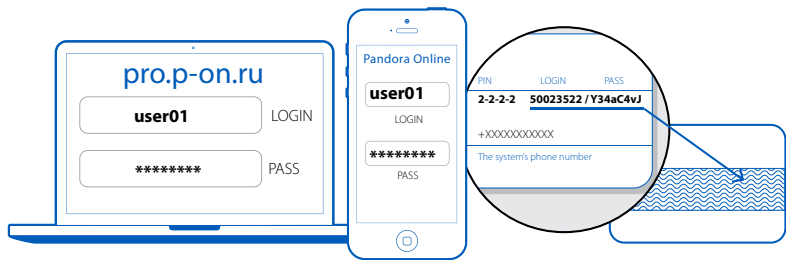

Pandora DXL-3050L service-security system

Event history

Event history holds more than 100 different types of events that can happen to the system. Every event is saved with date, time, coordinates (GPS/GLONASS receiver is required, sold separately) and status of all control zones at the moment the event has occurred. Pandora DXL-3050L has limitations by the number of events in the history. Storage of event history life is no less than 1 month.

Event history		
18 of January		
09:00	Arming	165 Fleet St, London EC4A 2DY, UK 09:00
08:35	Disarming	218 st Johns street, London ECTV 4AT, UK 08:35
08:24	Engine start	218 st Johns street, London ECTV 4AT, UK 08:24
17 of January		
18:34	Arming	218 st Johns street, London ECTV 4AT, UK 18:34
18:00	Disarming	165 Fleet St, London EC4A 2DY, UK 18:00
17:50	Engine start	165 Fleet St, London EC4A 2DY, UK 17:50
09:00	Arming	165 Fleet St, London EC4A 2DY, UK 09:00

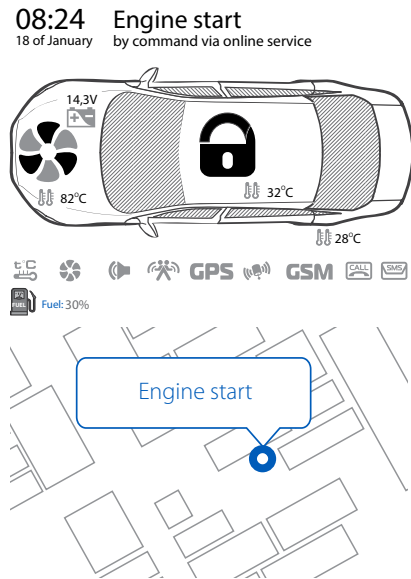

User manual

System status information

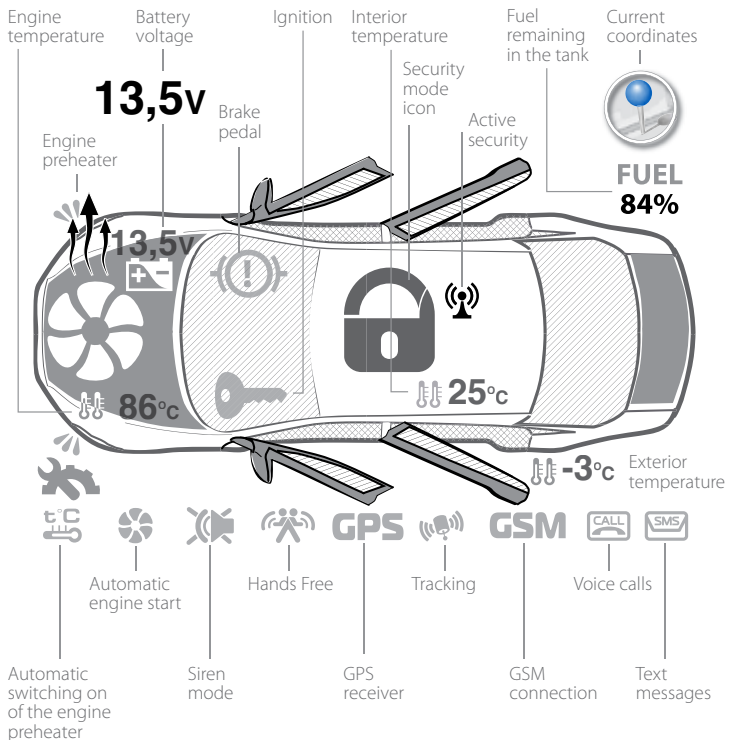

Security and warning zones

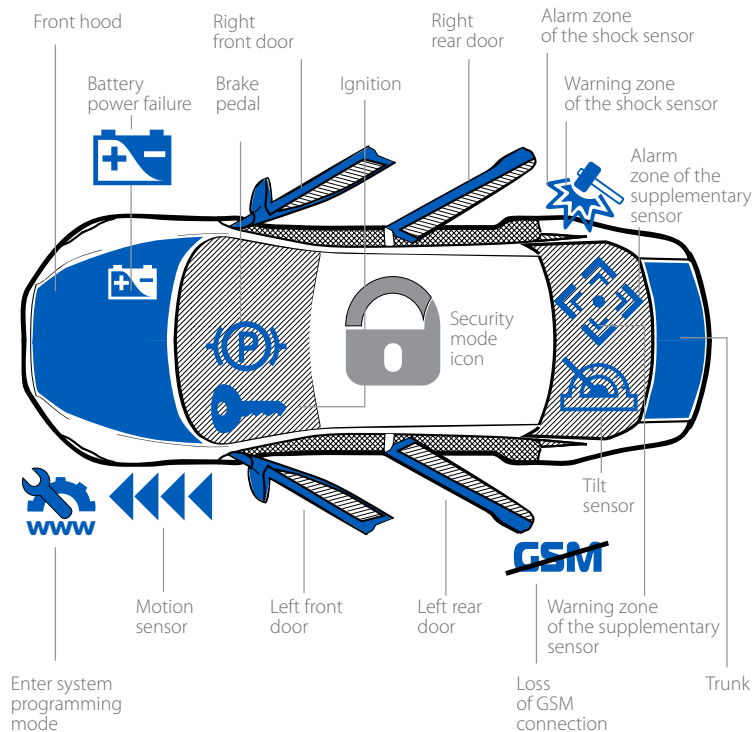

ADDITIONAL INFORMATION

Glossary of terms

AlarmStudio – an installation helper software that is to be installed on a Windows PC (preferably, laptop). AlarmStudio allows changing any parameters in the system and provides installation tips for particular cars. Easy to use and intuitive, AlarmStudio is required for in-depth and highly customized installation. Installation without AlarmStudio, although entirely possible, may be incomplete and lacking in functionality.

Base Unit – it is a small box that acts as a 'brain' of the system. It contains a printed circuit board, sensors and supplementary devices like 3D accelerometer and sockets for connecting it to car systems. Powerful processor unit and ingenious algorithms allow for hundreds of programmable parameters, accessible via AlarmStudio (and via VALET button for some).

Car alarm system – a set of third-party electronic devices that are installed in a car body and connected to its electric and data networks in order to provide enhanced security.

Car service-security system – same as car alarm system but with more service options, e.g. telemetry, remote engine start, various control options.

Channel – a name we use in our service-security systems to indicated a combined position and function of particular output socket and corresponding wiring.

Original security system – a built-in security system that is present on some car models. You can set up particular logic of interaction between this system and ours – control over it or a slave mode.

Telemetry – in car service-security systems is a combined capability to gather, process and convey to user various data regarding the car – temperatures, voltages, fuel level, sensor data, etc.

Timer channel – a term we use in our service-security systems to name channels that activate additional options or accessories (e.g. seat heating, light path, additional block relays). Any channel (output) can be set as timer channel, that can be activated from the remote, or incorporated into scheduled and sequential routines. To assign timer channels, use AlarmStudio.

System modules layout

Ask the installer to mark system's modules on the picture provided. This information can be important for diagnostics in case system malfunctions.

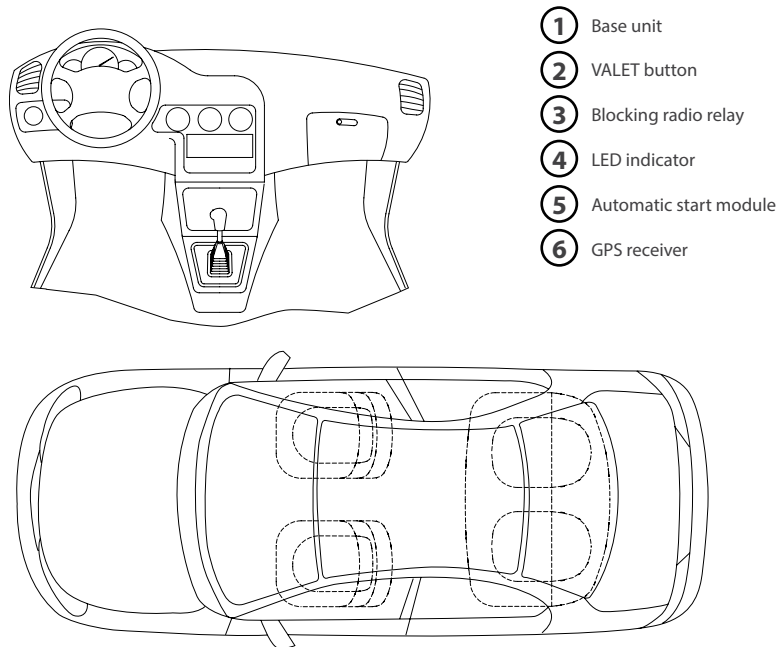

Warranty obligations

Manufacturer guarantees correct operation of the service-security system if exploitation, installation, storage and transportation conditions described in this manual were met.

The system should only be used according to installation scheme and user manuals.

The system is meant to be installed by the professional car electronics installers. We recognize that outside Russia the system can be installed by amateurs – those installations are still a subject of limited warranty. The installer should fill in installation certificate that is included in this manual.

Parts malfunctioning during warranty period on the fault of the manufacturer should be repaired or replaced by the installation center of the manufacturer or by certified service center. List of certified service centers outside Russia can be found on pandorainfo.com

The user loses the right for warranty services in the following cases:

- when warranty period expires;
- if exploitation, installation, storage or transportation conditions were not met;
- if there is mechanical damage of the external parts of the system after it is sold. This includes: fire damage, consequential damage in case of car accident, aggressive liquids and water seeping damage, damage caused by improper use;
 - if the damage was caused with incorrect settings and parameter adjustment;
 - if system devices are replaced with any devices that are not recommended by the manufacturer;
 - if manufacturer sealing is broken;
 - if there is no properly filled warranty card and installation certificate.

Warranty period is 3 years since the moment of purchase, but no more than 3,5 (three and a half) years since the moment of production.

This warranty does not include batteries of the remotes, as they have their own service life time.

Maintenances and repairs of the system with expired warranty period are carried out at the expense of the user on a separate contracts between the user and the installer/service center.

Transportation rules

Products should be transported in the original packaging by any means of transport as long as they are protected from mechanical damage and precipitation.

Packaged products should be stored on racks in piles of 6 or less boxes, in enclosed, dry, heated rooms (no less than 1m from heating) which exclude possible interaction with moisture, oil products and damaging environmental factors.

Installation certificate

I, the undersigned _____
Position, name

professional installer, certify that installation of the service-security system, specified below, was carried out by me in accordance with manuals and schemes provided by the manufacturer.

Car specifications:

Car model _____

Type _____

ID number (VIN) _____

Registration number _____

Security system specifications:

Model Pandora DXL-3050L

Serial number _____

Service center name, full address and installer's stamp _____

Signature _____/_____

Signator

Work accepted _____/_____

Signator

Date « ___ » _____ 20__y

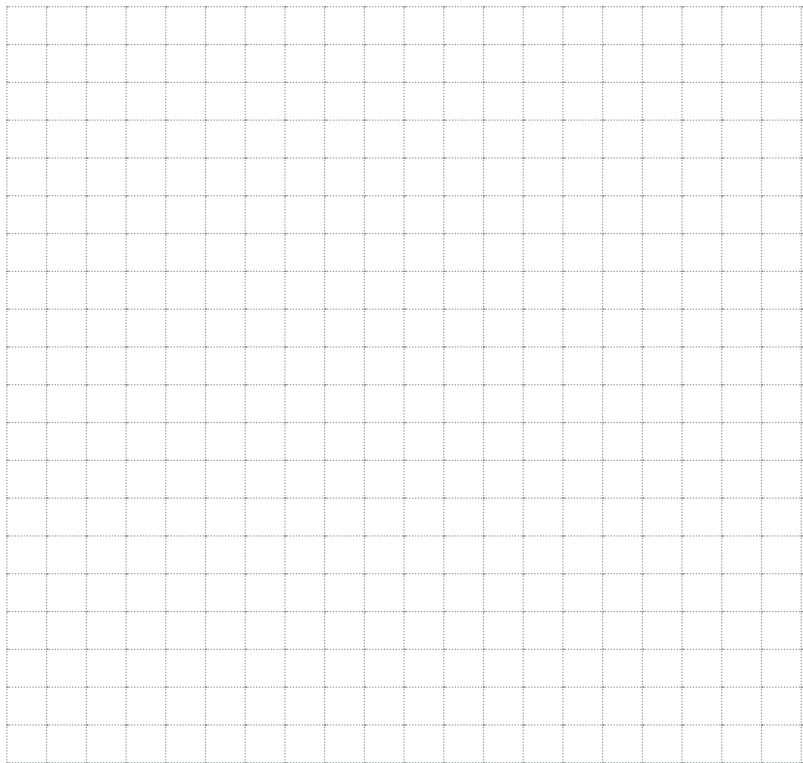

Acceptance certificate

Pandora DXL-3050L is in conformity with Electromagnetic Compatibility Directive EMC 2004/108/EC and R&TTE Directive 1999/5/EC

Serial number _____

Date of production _____

Responsible person's signature

(stamp)

Packager _____

Signature (personal stamp)

Warranty card

Model Pandora DXL-3050L

Serial number _____

Date of purchase « ____ » _____ 20__y

Seller's (installer's) stamp

Seller's signature _____