

## Pandora would like to thank you for choosing our DXL-1820L/1830L service and security system

**Pandora** is a brand of Russian Experimental Engineering Factory, a full production cycle electronics R&D facility. We design and produce car service-security systems for more than 10 years and have reached a considerable success on our domestic markets – biggest security system markets in the world. Our systems are made to withstand severe weather conditions and criminal situation of northern Eurasia.

**Pandora DXL-1820L/1830L** is a premium car service-security system, built for cars with on-board voltage of 12V. It is a complex engineering solution which includes car security system, telemetry, remote and automatic engine start and various service options, all controlled from your OEM key remote, smartphone or online service. This system is designed to be all-in-one car service and security solution and requires no additional modules: it includes algorithmic keyless bypass that works with many popular car models. For even more convenience, it allows remote control over Webasto or Eberspaecher preheaters – and even sequential use for automatic engine start.



### WARNING!

IT IS STRONGLY ADVISED TO HAVE PROFESSIONAL CAR MECHANIC INSTALLING THE SYSTEM. CERTIFIED INSTALLERS ARE RARE OUTSIDE RUSSIA, BUT ANY CAR ELECTRONICS INSTALLER SHOULD BE ABLE TO INSTALL PANDORA DXL-1820L/1830L USING INSTALLATION SCHEME IN THIS MANUAL AND ALARMSTUDIO SOFTWARE. MOST FEATURES ARE HIGHLY DEPENDENT ON COMPETENT INSTALLATION. OUR SYSTEMS ARE THOROUGHLY TESTED FOR QUALITY, SO IF A FEATURE FAILS TO PRODUCE EXPECTED RESULTS, MOST LIKELY THE PROBLEM IS IN IMPROPER INSTALLATION.

It is essential for systems functioning that you read and understand instructions in this manual. Note that all radio devices are subject to interference, which could affect proper performance.

This device has limited external factors resistance. It should not be subjected to water beyond occasional splatter, or operated in temperatures outside -40 to +80 °C range.

**IMPORTANT! Note that this manual describes remote and manual functions for the most part. Functionality of the system is vast and would require a book-sized manual to fully describe. Instead we use a handy software named AlarmStudio that functions as both programming tool and an extended installation & functionality manual. It requires Windows and can be downloaded at [pandorainfo.com](http://pandorainfo.com)**

## Table of contents

<b>General information</b>	<b>4</b>
System features	4
System set	5
Siren sounds and turn light signals	6
Meaning of indicator LED colors	6
<b>Control over system</b>	<b>7</b>
Arming/disarming using radio tag button	7
Arming/disarming in Hands Free mode	7
Arming/disarming in slave mode	7
Immobilizer mode	8
Antihijack mode	8
Immobilizer code using original car controls	9
Replacing immobilizer tag battery	9
Control over system in case of emergency	9
<b>Control over system via phone</b>	<b>11</b>
Changing core settings via phone	14
Pandora online information service pandora-on.com and mobile apps	16

## Wiring diagrams

### Installation and configuration of the system

General installation requirements	23
Wiring description	24
Programming system and entering PIN-code	25
Configuring system settings via the wireless interface 2,4 GHz	26
Entering the programming menu using VALET button	27
Changing core settings using VALET button	28
Additional devices	33

### Additional information

Glossary of terms	35
System modules layout	36
Warranty obligations	38
Installation certificate	39
Acceptance certificate	40
Warranty card	40

## GENERAL INFORMATION

### System features

#### Base unit

- Mobile app support for iOS and Android.
- Individual PIN-code to disarm and switch off immobilizer.
- Hands Free mode for arming/disarming without using a remote.
- Antihijack 1 and Antihijack 2 modes.
- Automatic arming.
- Validator mode.
- Algorithms of keyless bypass of original immobilizer.
- Integrated GSM-interface.
- Built-in 2,4 GHz module with support of Bluetooth 4.2 Low Energy protocol.
- Dialog coding of control commands.
- Individual 128-bit encryption key.
- RC blocking relay (2,4 GHz, frequency, up to 3 units can be connected).
- Built-in integral accelerometer for determining motion and shocks with adaptive processing algorithm and sensitivity controls via the remote.
- Advanced process of sensor data reading, eliminating false alarm possibilities.
- Built-in temperature sensor.
- Software updates via built-in micro-USB socket.

#### Immobilizer tags

- Dialog coding of control commands.
- Individual 128-bit encryption key.
- Built-in LED indicator.
- Built-in button to control over security modes.
- Built-in integral accelerometer.
- CR-2032 battery (not shipped with the system).

#### Car security zones

Pandora DXL-1820L/1830L service-security system guards following independent zones:

- car doors perimeter (separate for every door)
- front hood triggers
- trunk triggers
- ignition trigger
- brake pedal button
- triggering of the shock sensor (warning level)
- triggering of the shock sensor (alarm level)
- triggering of the motion sensor
- triggering of the tilt sensor
- critically low on-board voltage
- marker lights left on notification when arming\*

### System set

1. Base unit	1
2. Tag 2,4 GHz	2
3. Leather case for tags	1
4. Main cable	1
5. Cable with VALET button and three-colored light indicator	1
6. Fastening kit	1
7. User installation manual	1
8. Plastic card with individual secret code	1
9. Packaging	1
10. Beeper (compact sound emitter)	1
11. Engine temperature sensor	1

**Manufacturer reserves the right to change set and construction of the product to improve its technological and operational parameters without notification.**

\* Availability of this function depends on car make and model

## Siren sounds and turn light signals

Signal name	Signal description
Alarm mode, PANIC mode	Incessant sound and light signals for 30 seconds
Arming	1 sound and 1 light signals
Disarming	2 sound and 2 light signals
'Sensors triggered' signal when disarming	4 sound and 4 light signals
'Sensor malfunction' signal when arming	4 sound and 4 light signals
Sensor warning level triggered	3 sound signals
Car search	5 sound and 5 light signals

## Meaning of indicator LED colors

Indicator status	Meaning
Short red flashes	The system is armed
Lit red	The system is preparing for automatic arming
Orange flash	Confirms VALET button press
Green flashes	Confirms a number of recorded remotes (when switching on ignition)
Red and green flashes	PIN-code confirmed
Faded	The system is disarmed

## CONTROL OVER SYSTEM

### Arming/disarming using radio tag button

To arm/disarm the system, RF tag should be in radio coverage area. The system produces a protected (AES-128 encryption) interactive high-speed exchange of authorization codes in the frequency range 2,4 GHz on one of 125 channels. To arm the system when the ignition is switched off, shortly press the tag button. The system will confirm the command receiving with 1 short sound signal and 1 flash of turn indicators. To disarm the system, shortly press the tag button. The system will confirm the command receiving with 2 short sound signals and 2 flashes of turn indicators. Each button press will be confirmed with LED indicator flash of the tag that indicates the battery is functioning correctly. If LED indicator does not flash or light, the tag battery should be replaced (see 'Replacing immobilizer tag battery' section).



### Arming/disarming in Hands Free mode

The system allows for programmable **Hands Free** arming and disarming. To arm the system, when the engine is not running, move with the remote tag away from the car at a distance greater than the regular radio coverage (10 meters for 2,4 GHz) – the system will be armed automatically. To disarm the system, move toward the car with remote tag. Enabling/disabling this function can be performed with a phone (see 'Control over system via phone' section).

### Arming/disarming in slave mode

In this mode it is possible to monitor the status of original security system of the car via CAN-bus or by analog inputs. When arming and disarming original security system, Pandora will be armed and disarmed respectively. The presence of a tag in the radio zone is not required, but at the beginning of motion if the tag is not detected by the system, the engine will be blocked.

There is an option in the system settings named 'Disable disarming when the tag is not present'. When this option is enabled, disarming procedure will be performed only if there is a tag in the radio zone.

## Immobilizer mode

This mode is enabled by default, use a phone to disable this mode (see 'Control over system via phone' section). When engine is running, base unit of Pandora security system performs a search for immobilizer tags in radio zone. If no tags were detected, LCD remote will play '**NO TAG FOUND**' ringtone. If no radio tags were detected when the ignition is switched on, the system will block the engine with all radio relays that were programmed into the system. Engine blocking will only occur when motion sensor detects movement of the car. If additional analogue blocking relays were installed, they will block the engine immediately, before or when the car starts moving, it depends on system settings.

## Antihijack mode

This mode is disabled by default, use a phone to enable this mode (see 'Change settings via phone' section). **Antihijack mode** helps to prevent aggressive seizure of the car using delayed engine blocking on door opening.

Every time when the engine is running on opening/closing a door, immobilizer requests response from a remote using unique algorithm. After a door was opened while the engine is running, if the system cannot detect a radio tag, the engine will be stopped after 1 minute (general safety requirement). '**ENGINE BLOCKING WARNING**' ringtone will play before blocking.

If engine blocking is performed via radio relay after warning signals are over or on new attempts to start the engine, immobilizer will only allow the engine to start when the car is not moving, and will block it again if it starts movement. Immobilizer will be in active mode in no more than 2 seconds after the ignition is switched on. If the car starts moving, the immobilizer will block the engine for 15 seconds. When registered tag appears in the radio zone, blocking will be canceled and the system will return to the normal operation.

If the engine is blocked via analog relay, engine operation will be stopped after warning signals are over, until a registered tag appears in the radio zone or on registering movement – depending on the settings.



**WARNING!**  
ANTIHJACK MODE IS NOT LEGAL IN SOME COUNTRIES.

## Immobilizer code using original car controls

Code immobilizer is a function that allows disarming, disabling blocking and controlling timer channels using original car controls (button, lever or pedal). To enter immobilizer code, programmed button (lever, pedal) should be pressed a number of times equal the digit of the code. Pauses between presses should not exceed 1 second. Pauses more than 1 second will be interpreted as the start of next digit input. Immobilizer code can consist max of 4 digits from 1 to 9.

After entering a correct immobilizer code, depending on the settings, either the engine blocking will be lifted or a programmed timer channel will be activated or the system will be disarmed.

## Replacing immobilizer tag battery

Carefully open the cover of the tag's battery compartment. Extract discharged battery and insert a new one keeping in mind the correct polarity. Replacing a battery will not cause a loss of tag code information, as authorization data is stored in the non-volatile memory of the MCU.

Carefully close the cover of the tag's battery compartment. All elements of construction should be rigidly locked in places. If it is so, the tag can be operated as usually.



## Control over system in case of emergency

Use a phone to deactivate the system quickly. To disarm the system via a phone, call the system's number. When it answers, dial command **0\***. If the call is not made from the owner's number, guest PIN-code should be entered. Factory set guest PIN-code is **1-2-3-4**. To switch off immobilizer RF tag/Antihijack mode, dial command **998\*** (after dialing, enter individual PIN-code that is located on the owner's plastic card).

If the system cannot be deactivated via a phone, apply emergency disarming/switching off immobilizer RF tag using VALET button.

## Emergency disarming/switching off immobilizer using VALET button

In case you cannot disarm the system using a remote, owner's individual PIN-code can be used.

Individual PIN-code is written on the owner's plastic card under protective layer. Erase the protective layer and use VALET button to input PIN-code.

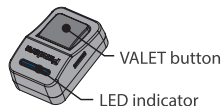

1. Using VALET button, input the first digit of the code (press the button a number of times, equal to the first digit; pauses between presses should not exceed 1 second). The system will confirm with red LED indicator flash.

2. Similarly input the second, third and fourth digit. Every input will be confirmed with red LED flash.

3. The system will confirm correct PIN-code with red and green flashes of LED indicator. If the input was incorrect, it will be indicated with long red flash. New input can be attempted after 5 seconds.

#### If immobilizer/Antihijack mode is activated:

4. Using VALET button, input PIN-code. Factory preset PIN-code is **1-1-1-1** (4 presses with pauses for 2 seconds).

5. The system will confirm correct PIN-code with red and green flashes of LED indicator and will enter programming mode. New input can be attempted after 5 seconds.

6. To switch off immobilizer/Antihijack function, press VALET service button 15 times (pauses between presses should not exceed 1 second). The LED will be lit green.

7. Input individual PIN-code similar to emergency disarm. The system will confirm correct PIN-code with 2 short signals of the siren and with red flash of LED.

8. To activate immobilizer/Antihijack function, enter level 15, the system will confirm it with red flash of LED. Press VALET button once, the system will confirm it with green flash of LED and with 1 short signal of the siren.

For emergency arming when the engine is stopped, press and hold VALET button for 3 seconds. The system will be armed in 30 seconds.

While there is a countdown, the LED will be lit red.



**WARNING!**  
MAKE SURE THAT PROTECTIVE LAYER ON THE OWNER'S PLASTIC CARD IS INTACT AFTER THE INSTALLATION OF THE SYSTEM. PLASTIC CARD HOLDS INDIVIDUAL PIN-CODE.

## CONTROL OVER SYSTEM VIA PHONE

Call the system's phone number. When it answers, enter command code.



**WARNING!**  
IF THE CALL IS NOT MADE FROM THE OWNER'S NUMBER, GUEST PIN-CODE SHOULD BE ENTERED. FACTORY SET GUEST PIN CODE IS 1-2-3-4. AFTER THE SYSTEM IS INSTALLED, PLEASE CHANGE FACTORY SET PIN-CODE.

#	Return to previous menu/state	6 6 6 *	Enable engine blocking
*	Repeat the last message	9 9 9 *	Disable engine blocking
1 *	Arming	2 5 8 *	System information
0 *	Disarming	9 9 8 *	Disable immobilizer tag
1 0 *	Silent arming	8 8 8 *	Enable immobilizer tag
0 0 *	Silent disarming	2 2 2 *	Disable Hands Free mode
9 *	Help	2 2 3 *	Enable Hands Free arming
0 9 *	Event history	2 2 4 *	Enable Hands Free disarming
1 5 *	Tow truck mode	2 2 5 *	Enable Hands Free disarming only with autom. start
1 0 0 *	Request GSM account balance	7 8 9 *	Enable automatic engine start
1 2 3 *	Start the engine/prolong heating	9 8 7 *	Disable automatic engine start
3 2 1 *	Stop the engine	2 9 7 *	Call ended
3 3 3 *	Switch on add. function using F via CAN	5 5 1 *	Enable valet mode (see description below)
5 0 0 *	Request current coordinates	5 5 2 *	Disable valet mode
4 5 6 *	Switch on additional channel	1 5 6 *	Switch on preheater
6 5 4 *	Switch off additional channel	6 5 1 *	Switch off preheater

#### Control via speed dial DTMF commands

**For example:** To have simple access to engine start function, create a new contact in the contact list of your phone, name it 'Engine start', for instance, and add the number in the following format: **+XXXXXXXXXXXX,123\*,297\***, where:

'+XXXXXXXXXXXX' – the system's phone number,

'\*' – pause is a feature of the phone (can be displayed as the 'P', see the instructions of the phone),

'123\*' – remote engine start DTMF command,

'297\*' – end call DTMF command.

Contact can be added as a speed dial to any of the free button. To have simple access to engine start function a phone other than the main owner's phone, create contact in the following format:

+XXXXXXXXXXXX,1234,123\*,297\*, where:

'1234' – guest PIN-code.

#### Enable/Disable maintenance/valet mode

1. Call system's number. Wait for answer.
2. To enable maintenance/valet mode, dial 'Enable maintenance/valet mode' DTMF command **551\*** (engine must be running, radio tag on the 2,4 GHz should be in range if immobilizer/Antihijack mode is active).
3. Enter individual PIN-code that is located on the owner's plastic card.
4. To disable maintenance/valet mode, dial **552\*** DTMF command.

#### Voice help

The system has voice help menu. During voice call to the system, dial **9\*** and listen to the information about system control commands. To end session, hang up the phone.

#### Repeat the last message

To repeat any message, press \* during a voice call to the system.

#### Arming/disarming

1. Call the system's number. Wait for answer.
2. Dial **1\*** to arm or **0\*** to disarm.  
For silent arming dial **10\*** or **00\*** for silent disarming.
3. The system will confirm: 'Arming/Disarming'.

To end session, hang up the phone.



WARNING!  
ONLY ENABLE REMOTE START IF YOUR LOCAL LEGISLATION ALLOWS DRIVERLESS CARS TO HAVE WORKING ENGINE.

#### Enabling/disabling automatic engine start

Pandora system has function of promptly disabling automatic engine start.

1. Call the system's number. Wait for answer.
2. Dial **987\*** to disable all automatic engine starts or **789\*** to enable all automatic engine starts.
3. The system will confirm execution.

To end session, hang up the phone.

Automatics starts can be enabled again by dialing **789\*** (all previous settings will remain intact).

#### Locking/unlocking the engine

You can block car's engine using any phone. The engine will remain blocked until phone command 'Unlock engine' will be sent. This blocking cannot be disabled using a remote.

1. Call the system's number and wait for answer.
2. Dial **666\*** to enable engine blocking or **999\*** to disable engine blocking (after dialing, you will need to enter individual PIN-code that is located on the owner's plastic card).

#### Request current coordinates

1. Call the system's number. Wait for answer.
2. Dial **500\***.
3. The system will confirm: 'Current coordinate sent via text message' and will send text message with coordinates and a web link to a map to your phone.

To end session, hang up the phone.

#### Request GSM account balance

1. Call the system's number. Wait for answer.
2. Dial **100\***.
3. The system will confirm: 'Balance information sent via text message' and will send text message with account balance information to your phone.

To end session, hang up the phone.

## Tow truck mode

This mode is intended for car transportation with preservation of arming function. **Tow truck mode** can be activated only when armed, it will be deactivated automatically when disarming.

1. Call the system's number. If the system is in **PANIC mode**, receive emergency call. Wait for answer.
2. Dial **15\*** to enable Tow truck mode, the system will disable motion, shock and tilt sensors.
3. To disable this mode, disarm the system.

To end session, hang up the phone.

Similarly any other system command can be entered.

## Changing core settings via phone

To enter settings programming mode:

1. Disarm.
2. Call the system's number, wait for answer.
3. Switch ignition on for 1-3 seconds, then off.

The system will switch into settings programming mode.



**WARNING!**  
THERE ARE ONLY TWO WAYS TO CHANGE THE OWNER'S PHONE NUMBER:  
1. VIA PHONE, USING CORE SETTINGS MENU.  
2. VIA COMPUTER AND PANDORA ALARMSTUDIO SOFTWARE.

**Example of changing the owner's system number:**

1. Enter the setting menu via phone according to the instruction above.
2. Dial DTMF command **1\*** (phone number settings) and **1\*** (owner's system number).
3. Enter new owner's number in the format **\*XXXXXXXXXXXX#** ( the system recognizes '\*' as '+').
4. To confirm, dial **1\***.

1 * Phone number settings	1 *	Owner's number -> #
	2 *	Additional owner's number -> #
	3 *	Second additional owner's number -> #
	4 *	Account balance inquiry number -> #
	5 *	System's number -> «#»
2 * Settings of the voice calls	1 *	Voice calls on alarm
	2 *	Voice calls on triggering warning level of the sensors
	3 *	Voice calls on engine start
	4 *	Voice calls on engine stop
	5 *	Voice calls on restoring GSM connection
	6 *	Voice calls on disarming
	7 *	Voice calls on entering programming mode
	8 *	Voice calls when radio relay connection is lost
	9 *	Voice calls when on-board voltage is low
	0 *	Voice calls on accident
3 * Settings of the text messages	1 *	Text messages on alarm
	2 *	Text messages on triggering warning level of the sensors
	3 *	Text messages on engine start
	4 *	Text messages on engine stop
	5 *	Text messages on restoring GSM connection
	6 *	Text messages on disarming
	7 *	Text messages on entering programming mode
	8 *	Text messages when radio relay connection is lost
	9 *	Text messages when on-board voltage is low
	0 *	Text messages on accident
4 * Immobilizer settings	1 *	Immobilizer (on/off)
	2 *	Antihijack
5 * Additional settings	1 *	Changing guest PIN-code
	2 *	Entering as guest
	3 *	Remote blocking
	5 *	Set threshold voltage for sending text message
	6 * Automatic engine start settings	1 *
2 *		Set up time for automatic start
3 *		By voltage
4 *		Set up voltage for automatic start
5 *		By temperature
6 *		Set up temperature for automatic start
7 *		By period
8 *		Set up period for automatic start
7 * Sensor sensitivity settings	1 *	Settings of the warning level of the shock sensor sensitivity
	2 *	Settings of the alarm level of the shock sensor sensitivity
	3 *	Settings of the motion sensor sensitivity
8 * Settings of saving mode	4 *	Settings of the tilt sensor sensitivity
	5 *	Settings of the warning level of the supplementary sensor sensitivity
	6 *	Settings of the alarm level of the supplementary sensor sensitivity
	1 *	GSM connection
	2 *	Money saving mode of the GSM connection
	3 *	Voice calls in roaming service
9 * Current time and date settings	1 *	Set up date
	2 *	Set up time

**NOTE:** Engine start via temperature is available only if temperature sensor is connected. The sensor availability depends on the system set.



## Pandora online information service pandora-on.com and mobile apps

### Registration

Visit pandora-on.com website and register, following the instructions.

### System login

After completing of the registration process, you can login to online service via computer's web browser or via special mobile apps for the Android (Pandora Online) and iOS (Pandora Pro). Only the main functions are available in these apps with DXL-1820L/1830L.

### Mobile apps

These apps are free and available through your device's app store (AppStore, Google Play). To access the app, use the login data received from the service at the registration stage.

### Adding a car to the online service

Internet service pandora-on.com can support simultaneously several telemetry systems, installed on various cars (private car park). Only the main functions are available in online service with DXL-1820L/1830L.

To add a telemetry system (car) to the service, press 'Add car' button and go through the process of adding, following the instructions.

To add a car, individual owner's card with registration information is needed (shipped with the system).

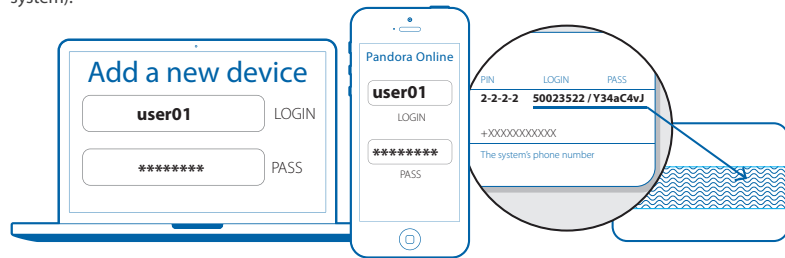

Pandora DXL-1820L/1830L service-security system

### Event history

Event history holds more than 100 different types of events that can happen to the system. Every event is saved with date, time, coordinates (GPS/GLONASS receiver is required) and status of all control zones at the moment the event has occurred. Storage of event history life is no less than 1 month.

Event history	
18 of January	
09:00	Arming 165 Fleet St, London EC4A 2DY, UK 09:00
08:35	Disarming 218 st Johns street, London EC1V 4AT, UK 08:35
08:24	Engine start 218 st Johns street, London EC1V 4AT, UK 08:24
17 of January	
18:34	Arming 218 st Johns street, London EC1V 4AT, UK 18:34 pandora-on
18:00	Disarming 165 Fleet St, London EC4A 2DY, UK 18:00 auto
17:50	Engine start 165 Fleet St, London EC4A 2DY, UK 17:50 time
09:00	Arming 165 Fleet St, London EC4A 2DY, UK 09:00

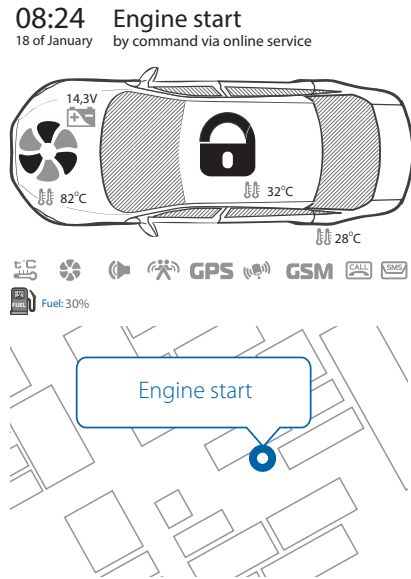

User manual

## System status information

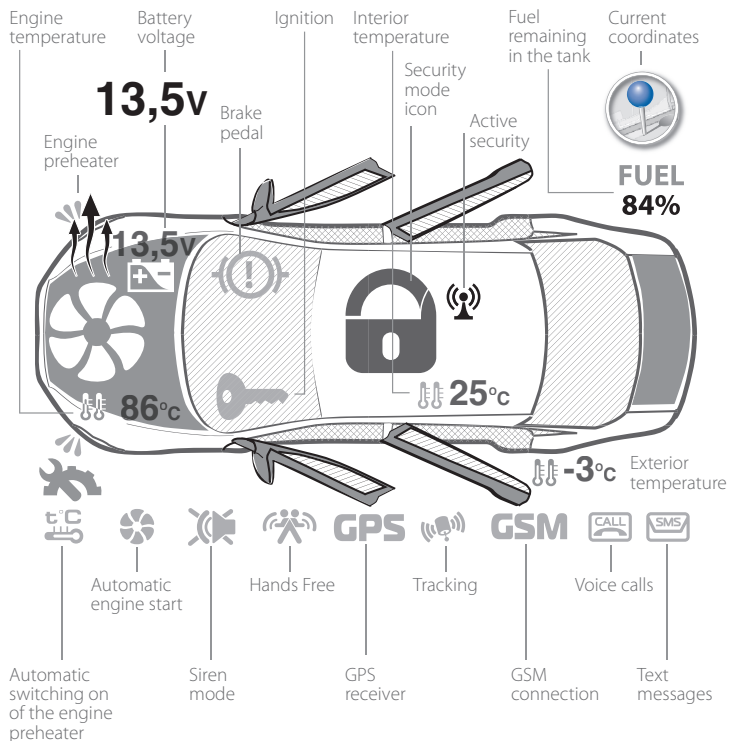

## Security and warning zones

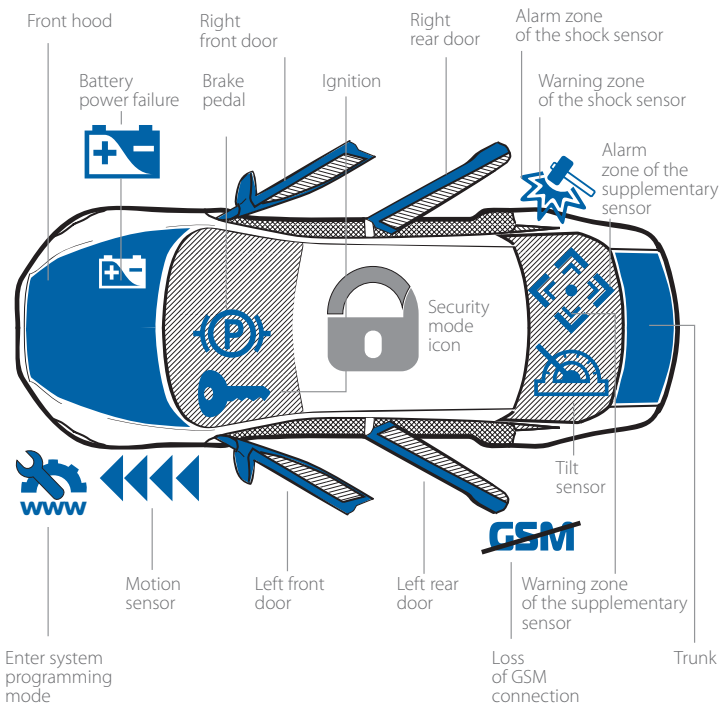

**WARNING!!!**

For proper installation a connected laptop with AlarmStudio software is required. Switch the system to programming mode (see page 25) and select your car model in AlarmStudio for detailed installation instructions. AlarmStudio can be downloaded from [pandorainfo.com](http://pandorainfo.com)

**WARNING!!!**

Do not accidentally shield the antenna!

MODEL: DXL-182OL/1830L

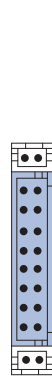
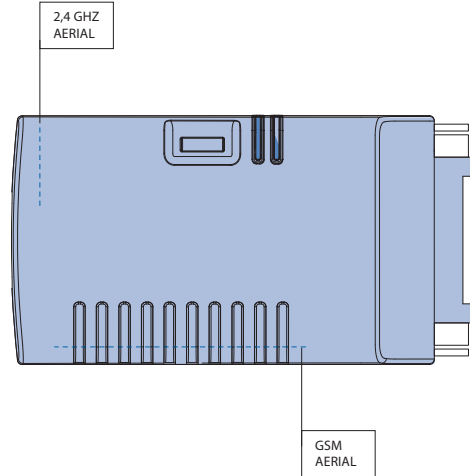
**Main socket**

1	White		DATA TX • TO ADDITIONAL DEVICES
2	Red/Black	(-) 200mA	OUT-6 • BEEPER
3	Orange/White		CAN1-HIGH
4	Yellow/White	200mA	CAN2-HIGH / OUT-2 • OPENING CENTRAL LOCK
5	Grey	(-) 200mA	OUT-1/INP-1 • DOOR SWITCHES
6	Green	(-) 200mA	OUT-4/INP-4 • TO TURN LIGHTS
7	Blue/White	(+)	INP-5 • BRAKE PEDAL BUTTON
8	Black	(-)	GROUND
9	Blue		DATA RX • TO ADDITIONAL DEVICES
10	Brown/White	(-)	INP-3 • FRONT HOOD/TRUNK SWITCHES
11	Orange/Black		CAN1-LOW
12	Yellow/Black	200mA	CAN2-LOW/OUT-5 • CLOSING CENTRAL LOCK
13	Blue/Black	(-) 200mA	OUT-3 • ENGINE BLOCK
14	Yellow	(+)	INP-2 • IGNITION SWITCH
15	Purple	(+) 2A	SIREN
16	Red	(+) Fuse 3A	POWER +12V

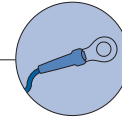

TEMPERATURE SENSOR

\* See 'System set' on page 5

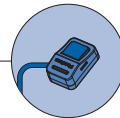
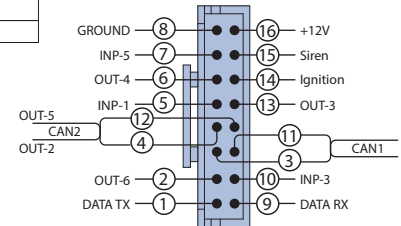
**MAIN SOCKET**

VALET | LED  
BUTTON | INDICATOR

Pandora

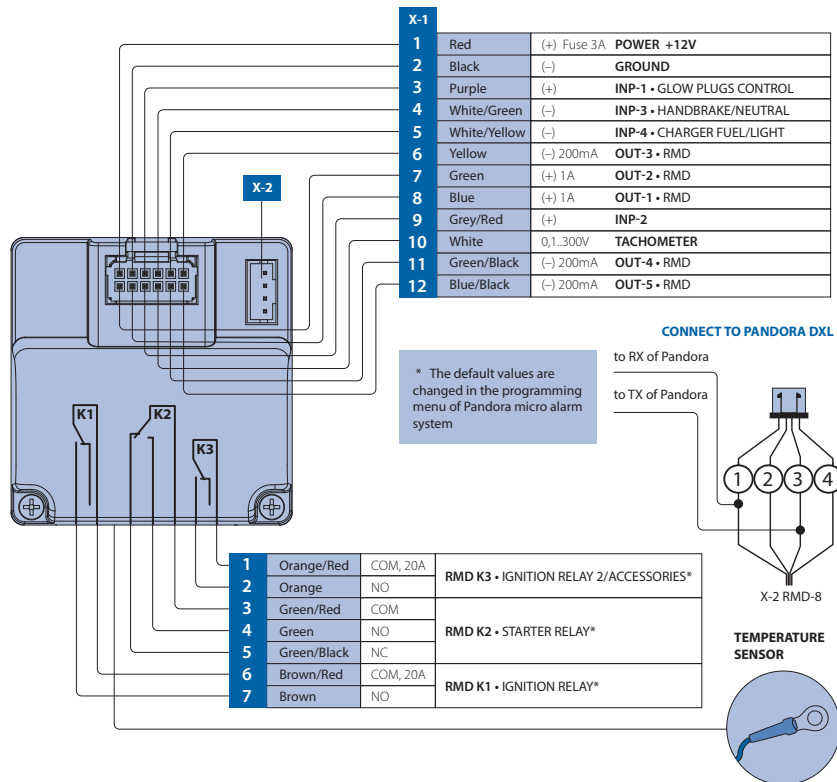

## INSTALLATION AND CONFIGURATION OF THE SYSTEM

### General installation requirements

- Only install base unit inside car interior.
- Install securely each system's component, as conditions of the car standard operation can harm functionality of the alarm system and cause damage to the car original systems, including the elements of safety in motion.
- The system installation should be performed when the system sockets and the negative battery terminal are disconnected.
- The base unit power supply should be switched off when connecting to CAN-bus.
- The system installation can be performed via twisting together or via lead-tin soldering followed by isolation of a switching place.
- When wiring, pay attention to sections and materials of switched conductors, if they are different, bring electrochemical potentials to the minimal difference. The isolation should not allow for moisture to reach wiring, as the presence of moisture will increase electrochemical destruction of wires (this is especially important for the large current circuits).
- Switched connections should be placed as high as it is possible in the cavities so water condensate will not form drops on the switching location.
- To avoid the destruction of compounds by car vibration, ensure that there is a bit of free length to the wiring, providing enough sagging.
- Do not allow wiring in places where the wires isolation can be destroyed by abrasion.
- Electronic system units should be placed sockets down and as high as possible to avoid condensate reaching electronic components through the socket.
- When installing base unit, secure it to the car body for correct operation of in-built shock sensor.
- All unused system wires during the installation must be insulated and secured to prevent accidental touching of a car body or other wires.

## Wiring description

### Base unit connection

**Wire 1** (White) (DATA TX) It connects to appropriate additional devices wires (optional).

**Wire 2** (Red-black) (OUT-6) Factory setting is Beeper. A negative output of additional channel with maximum load capacity 200mA. This output is multipurpose, it can operate in accordance with selected logic.

**Wire 3** (Orange-white) ('CAN1-High') It connects to appropriate CAN-High wire of the car.

**Wire 4** (Yellow-white) ('CAN2-High'/OUT-2) Factory setting is 'Open central lock'. A negative impulse of 0,8 seconds is formed on the wire to open central lock. Logic of the channel's operation can be set in the table of system outputs in AlarmStudio. Channel OUT-2 stops operating as an output when a car code with enabled digital CAN2-bus is chosen.

**Wire 5** (Grey) (INP-1/OUT-1) Factory setting is 'Door switches'. This wire connects to a wire that becomes grounded when the door opens. This input is multipurpose, it can operate in accordance with selected logic.

**Wire 6** (Green) (INP-4/OUT-4) Factory setting is 'Control turn indicators'. This wire connects to the hazard flashers button. This channel is multipurpose, it can operate in accordance with selected logic.

**Wire 7** (Blue-white) (INP-5) Factory setting is 'Brake pedal limit switch'. This wire connects to the brake pedal button where 12V voltage appears when the pedal is pressed (stop lights wire). Brake pedal signal is one of the system's security zones. This input is multipurpose, it can operate in accordance with selected logic.

**Wire 8** (Black) (ground) It should be connected to the car body in a grounding spot. This wire should be connected FIRST during installation.

**Wire 9** (Blue) (DATA RX) It connects to appropriate additional devices wires (optional).

**Wire 10** (Brown-white) (INP-3) Factory setting is 'Front hood and trunk limit switch'. This wire connects to appropriate wire that becomes grounded when the front hood opens. This input is multipurpose, it can operate in accordance with selected logic.

**Wire 11** (Orange-black) ('CAN1-Low') It connects to appropriate CAN-Low wire of the car.

**Wire 12** (Yellow-black) ('CAN2-Low'/OUT-5) Factory setting is 'Close central lock'. A negative impulse of 0,8 seconds is formed on the wire to close central lock. Logic of the channel's operation can be set in the table of system outputs in AlarmStudio. Channel OUT-5 stops operating as an output when a car code with enabled digital CAN2-bus is chosen.

**Wire 13** (Blue-black) (OUT-3) Factory setting is 'Blocking N.O.' . This output is used to control blocking relay with a normally open logic (it becomes grounded when switching on the ignition and security system is not armed). A negative output of additional channel with maximum load capacity 200mA. This output is multipurpose, it can operate in accordance with selected logic.

**Wire 14** (Yellow) (INP-2) Factory setting is 'Ignition'. This wire connects to ignition switch or to appropriate wire where 12V voltage appears when ignition is switched on and doesn't disappear until the moment ignition is switched off. This input is multipurpose, it can operate in accordance with selected logic.

**Wire 15** (Purple) ('siren') It connects to siren control wire (+) (maximum load current is 2A).

**Wire 16** (Red) ('Power supply' 12V) It should be connected to reliable conductor with constant voltage of 12V.

## Programming system and entering PIN-code

The system settings can be changed via computer. The system should be connected to a computer via standard micro-USB cable and a special piece of software – **Pandora AlarmStudio**.

**AlarmStudio can be downloaded from the official company web-site [pandorainfo.com](http://pandorainfo.com)**

### Entering programming menu:

1. Disarm the system, switch off the ignition.
2. Connect the base unit of the system to a computer via micro-USB cable.
3. Using VALET button, input service PIN-code. Factory preset PIN-code is **1-1-1-1**.
4. Using VALET button, input the first digit of the service code (press the button a number of times, equal to the first digit; pauses between presses should not exceed 1 second). The system will confirm

entering of the first digit with red LED indicator flash.



**WARNING!**  
IF YOU ARE AN INSTALLER, DO NOT ERASE PROTECTIVE LAYER OF THE OWNER'S PLASTIC CARD! IN CASE A CUSTOMER COMPLAINS ON ERASED PROTECTIVE LAYER OF THE CARD WITH THE INDIVIDUAL PIN-CODE, RE-INSTALLATION OF THE SYSTEM IS CARRIED OUT AT THE EXPENSE OF THE INSTALLER.

5. Similarly input the second, third and fourth digit. Every input will be confirmed with red LED flash.

6. The system will confirm correct PIN-code with red LED flashes and proceed to the programming mode. If the input was incorrect, it will be indicated with long red flash and the system will proceed to previous mode. New input can be attempted after 5 seconds.

#### Changing core settings via computer

The system allows programming all settings and updating software of the base unit via the interface micro-USB cable or via radio channel using a computer. It does not matter, whether base unit is installed into a vehicle or not. Software reads the current setting and allows changing them. If base unit has not yet been installed in the vehicle, it should be powered via micro-USB cable while programming. To program using a computer connected via cable, you need a standard micro-USB cable, a computer with Windows and a special piece of software – Pandora AlarmStudio.

#### In preparation to the programming following stages should be followed:

- connect micro-USB cable to any free USB socket of the computer;
- start Pandora AlarmStudio (can be downloaded from the web-site);
- enter the programming settings mode by entering the service PIN-code on the base unit using VALET button. Factory preset PIN-code is **1-1-1-1**.

If the software configuration is carried out via the radio interface of 2,4 GHz, special USB programmer RMP-03 should be used.

#### Configuring system settings via the wireless interface 2,4 GHz

To change the configuration of the system using a wireless interface 2,4 GHz, enter programming level 10. The system will await a wireless connection from the computer for 2 minutes.

#### Entering the programming menu using VALET button

After entering PIN-code, input the number of the required level using VALET button (press button the number of times equal to the level number; pauses between presses should not exceed 1 second). The system will confirm the number with red flashes of LED indicator and will proceed to the desired level. If the number is incorrect, the system will produce the series of red and green flashes and then will await for a new level input. To exit programming mode and save the settings, switch off the ignition.

Level 1	Recording remotes and radio tags into the system's memory
Level 2	Changing the factory preset service PIN-code
Level 3	Recording the idle speed to the system's memory
Level 4	Resetting to factory settings
Level 5	Programming of engine compartment module
Level 6, 7	Programming of radio relay 1 and 2
Level 8	Recording GPS/GLONASS receiver
Level 9	Reserved
Level 10	Configuring system settings via the wireless interface 2,4 GHz
Level 11	Programming validator code of immobilizer (Pin to Drive)
Level 12	Setting and updating GPS/GLONASS receiver
Level 13, 14	Reserved
Level 15	Emergency disabling of immobilizer
Level 16	Reserved
Level 17	Setting up keyless bypass of built-in immobilizer
Level 18	Reserved

## Changing core settings using VALET button

### Level 1 Recording remotes into the system's memory

Enter the first level of programming. Insert batteries to RF tags and record tags to the system memory (pair) one by one.

To pair the radio tag, press the control button on the tag and hold it until 6th LED flash (then release). If the recording was successful, the base unit will emit 1 beep.

Record supplementary tags in the same manner. Number of sound signals corresponds to the sequence of recording tags.

To finish the recording of the remote units into the system, VALET button should be pressed again, the status LED will produce series of red and green flashes; then switch on and off the ignition to leave the programming mode.



**WARNING!**  
IF THE CONTROL OVER SIREN IS CARRIED OUT USING RHM ENGINE COMPARTMENT MODULE, SIREN SOUND SIGNALS WILL NOT BE EMITTED DURING RADIO TAGS RECORDING!

### Level 2 Changing the factory preset service PIN-code

• Indicator LED is not lit. Press VALET button the number of times equal to the first digit of the new security code. Each pressing of VALET button is followed by red flash of the indicator. The interval between presses should not exceed 1 second.

• The input will be confirmed with red flash of indicator.

• Enter the other numbers in the same manner.

• The input of the fourth number will be confirmed by series of red and green LED indicator flashes.

• Enter all four numbers again.

• If you were able to correctly enter code twice, the indicator will produce series of red flashes and a new PIN-code will be recorded, the system will return to the programming mode.

• In case of the incorrect code input the indicator will be lit red and the system will return to a programming mode.

After the input is complete, the indicator fades, the system awaits a new programming level input.

### Level 3 Recording the idle speed to the system's memory

At this programming level the idle turns speed of the engine is recorded (into non-volatile memory). Upon entering this level you need to switch the ignition on and start the engine (it should be warmed-up and the idle speed should match a normal rate for the heated engine). Wait until the stable idle speed is reached (it takes about 30 seconds). Then press VALET button once.

Successful recording will be confirmed with 1 sound siren signal and with 3 signals in case of unsuccessful recording.

The ignition should be switched off after recording. While on this programming level, you can start and stop the engine many times – it will only be exited on VALET button press.

### Level 4 Resetting to factory settings

To reset to the factory settings, you need to enter programming level 4, then press and hold VALET button for 5 seconds until siren sounds. Once VALET button is released, the status indicator will confirm a successful reset to factory settings with a long red flash.

### Level 5 Programming of engine compartment module

1. Enter programming mode on level 5.

2. Perform programming according to the instructions to the device.

### Level 6, 7 Programming of radio relay 1 and 2

1. Select the desired level of the programming menu 6 or 7 for programming radio relays 1 or 2 respectively.

2. Connect the wire 1 of the radio relay to a grounded spot.

3. Apply power (+12V) on the contacts 3 and 4 of the radio relay. Siren will confirm radio relay recording to the memory with 1 beep.

4. After a successful radio relay recording, contact 3 should be disconnected and insulated, contact 4 should be connected to the wire where there is a constant 12V when the ignition is switched on and it does not disappear until the ignition is switched off.

### Level 8 Recording GPS/GLONASS receiver

Enter this level and connect power to the GPS/GLONASS receiver. Siren of the base unit will confirm successful recording with 1 beep.

## Level 10 Configuring system settings via the wireless interface 2,4 GHz

To change the configuration of the system using a wireless interface 2,4 GHz, enter programming level 10, the system will confirm the entering with red flash of LED indicator. The system will await a wireless connection from the computer for 2 minutes. If the waiting time limit has expired and the system was not connected to the computer, it will exit this level.

## Level 11 Programming validator code of immobilizer (Pin to Drive)

### 1. Select the button to set the secret validator code of immobilizer.

To do this, enter level 11 of programming and press the selected button (e.g. wheel 'volume up' button), LED indicator will confirm input with orange flashes. If there are no orange flashes when any button is pressed, then this button is not recognized by the system, select a different button. After the button was chosen, press VALET button. Security system will memorize the last pressed button (which was pressed before VALET button) as a button to enter PIN-code of immobilizer and will await input of the first digit of PIN-code.

### 2. Program the immobilizer deactivation PIN-code.

Enter the first digit by pressing the previously selected button (pauses between presses must be no more than 1 second). The base unit will confirm entering with red flash of LED indicator.

Input the second (third, fourth) digit by pressing the previously selected button. The base unit will confirm entering with red flash of LED indicator.

Input the required number of digits (up to 4) and then press VALET button. The system will confirm receiving of the secret validator code with long red flash of LED indicator and will expect for confirmation of PIN-code.

### 3. Confirm the immobilizer deactivation PIN-code.

Input PIN-code again similarly to the programming procedure and press VALET button. The system will confirm correct PIN-code with red and green flashes of LED indicator and will memorize PIN-code, then will proceed to the programming mode awaiting level input. Incorrect confirmation is indicated with long red flash of LED indicator, after that the system will return to a programming mode.

## 4. Disarming via validator code.

The system can be disarmed by entering validator code using programmed button. It can be done via a CAN-bus readable button (list of supported buttons can be viewed in status and command table in AlarmStudio) or via any other button connected by analogue to 'Code immobilizer (validator)' input programmed in the table of system inputs in AlarmStudio.

For example:

- when function is active, valuables can be left in the car;
- the system can be armed via VALET button; press and hold VALET button no less than 3 seconds, the system will be armed in 30 seconds and locks will be closed;
- the system can be disarmed by entering validator code via open trunk button, after that locks will be opened.

## 5. Additional authorization by entering validator code.

Validator (code immobilizer) is an additional car protection measure. Validator operation activates all blocking relays (both analogue and digital ones).

To activate this function, enable 'Switching off blockings only after entering validator code'. The function will be activated automatically in 20 seconds after engine start and immediately when arming.

When engine starts, the system awaits validator code input. If code was not entered, the system will activate all blocks via programming logic (on engine start, on moving automatic transmission selector/switching off handbrake, on movement start).

When maintenance mode is active, validator will be deactivated.

### To switch on maintenance mode:

- switch on the ignition;
- place the tag in radio coverage zone (if immobilizer/Antihijack is enabled);
- enter validator code;
- enable maintenance mode via the remote or by dialing DTMF command **551\*** and code from the owner's card.

### To switch off maintenance mode via validator code:

- switch on the ignition;
- place the tag in radio coverage zone (if immobilizer/Antihijack is enabled);
- enter validator code;



- press validator button again 10 times in no less than 20 seconds after entering validator code.

#### Emergency switching off 'Validator' mode:

1. For emergency switching off this function call the system's number and dial DTMF command **998\*** and code from the card.

2. This mode can be disabled by entering personal code from the plastic card on level 15 of programming menu (see Level 15 description on page 32).

#### Level 12 Setting and updating GPS/GLONASS receiver

To update the firmware of GPS/GLONASS receiver via the 2,4GHz wireless interface, run the GPS Loader software and enter the programming level 12. After entering, update software of GPS/GLONASS receiver.

#### Level 15 Emergency disabling of immobilizer

To deactivate the immobilizer/Antihijack function enter the programming level 15, the system will confirm the entering with green flash of LED indicator. Input the first digit of the secret code using VALET button (press the button a number of times, equal to the first digit; pauses between presses should not exceed 1 second). The system will confirm input with red flash of LED indicator. Enter the other three digits in the same manner. The correct input will be confirmed with 2 short sound signals of the siren and with red flash of LED indicator. To activate immobilizer/Antihijack function, enter level 15, LED will confirm input with red flash. Press VALET button once, siren will emit 1 short beep.

#### Level 17 Setting up keyless bypass of built-in immobilizer

This level enters programming mode to teach algorithmic keyless bypass of built-in immobilizer. LED indicator will be lit green when on this level. If system installation was performed correctly on successful engine start using a key, LED indicator will flash green and siren will emit a short signal. To save and finish, press VALET button. Now the system should be able to simulate key for remote starts. For more in-depth instructions, use AlarmStudio.

## Additional devices

### Expansion module RMD-8 (see diagram on page 22)

Expansion module RMD-8 is designed to be used in conjunction with Pandora DXL-1700L, DXL-1820L/1830L, 3050L and Professional service-security systems. RMD-8 allows to significantly expand the capabilities of a system, provides the ability to connect to the vehicle power circuits (up to 20A) and adds 8 additional programmable outputs (OUT) and 4 analogue inputs.

RMD-8 is mainly needed to allow remote engine start function via analogue connection when it is not possible to remotely start engine via CAN-bus.

Module provides control over basic parameters needed for correct and safe operation of the engine: temperature and engine speed, glow plugs control, state of oil lamp/charge and handbrake/neutral.

Name of parameter	Value
Current consumption	no more than 7mA
Supply voltage	9-15V
Operating temperature range	from -40to +85°C
<b>The maximum load current, dial-out</b>	
RMD OUT-1 (+)	1A
RMD OUT-2 (+)	1A
RMD OUT-3 (-)	200mA
RMD OUT-4 (-)	200mA
RMD OUT-5 (-)	200mA
RMD K1	20A
RMD K2	20A
RMD K3	20A
Permissible amplitude of tachometer signal	3-300V
Dimensions	45,5x44x17 mm

## Blocking radio relay

For Pandora DXL-1820L/1830L optionally blocking BTR-101 radio relay is available. Blocking radio relay with built-in accelerometer should be placed in the engine compartment. Herewith zone of built-in aerial 2,4 GHz should not be shielded.

Provide a rigid fastening to the car body or to the fixed wirings. It is forbidden to hide the module in wiring.

Radio relay power connects either from ignition or from a constant power wire. Radio relay is normally closed, blocking is carried out only on unauthorized movement.



**WARNING!**  
DO NOT PLACE RADIO RELAYS DIRECTLY ON ENGINE!

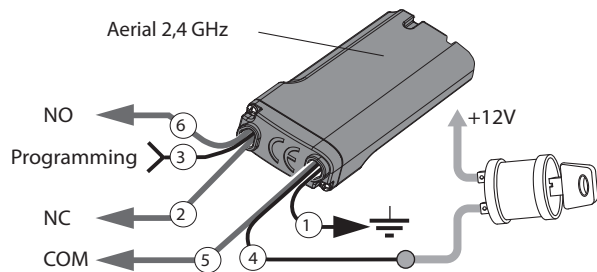

## ADDITIONAL INFORMATION

### Glossary of terms

**AlarmStudio** – an installation helper software that is to be installed on a Windows PC (preferably, laptop). AlarmStudio allows changing any parameters in the system and provides installation tips for particular cars. Easy to use and intuitive, AlarmStudio is required for in-depth and highly customized installation. Installation without AlarmStudio, although entirely possible, may be incomplete and lacking in functionality.

**Base Unit** – it is a small box that acts as a 'brain' of the system. It contains a printed circuit board, sensors and supplementary devices like 3D accelerometer and sockets for connecting it to car systems. Powerful processor unit and ingenious algorithms allow for hundreds of programmable parameters, accessible via AlarmStudio (and via VALET button for some).

**Car alarm system** – a set of third-party electronic devices that are installed in a car body and connected to its electric and data networks in order to provide enhanced security.

**Car service-security system** – same as car alarm system but with more service options, e.g. telemetry, remote engine start, various control options.

**Channel** – a name we use in our service-security systems to indicated a combined position and function of particular output socket and corresponding wiring.

**Original security system** – a built-in security system that is present on some car models. You can set up particular logic of interaction between this system and ours – control over it or a slave mode.

**Telemetry** – in car service-security systems is a combined capability to gather, process and convey to user various data regarding the car – temperatures, voltages, fuel level, sensor data, etc.

**Timer channel** – a term we use in our service-security systems to name channels that activate additional options or accessories (e.g. seat heating, light path, additional block relays). Any channel (output) can be set as timer channel, that can be activated from the remote, or incorporated into scheduled and sequential routines. To assign timer channels, use AlarmStudio.

## System modules layout

Ask the installer to mark system's modules on the picture provided. This information can be important for diagnostics in case system malfunctions.

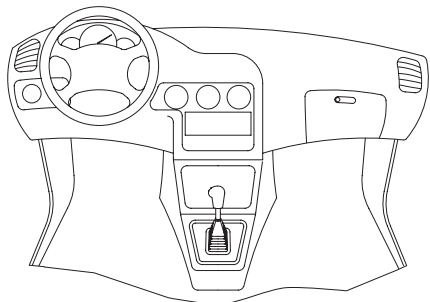

- ① Base unit
- ② VALET button
- ③ Blocking radio relay
- ④ LED indicator
- ⑤ Automatic start module
- ⑥ GPS receiver

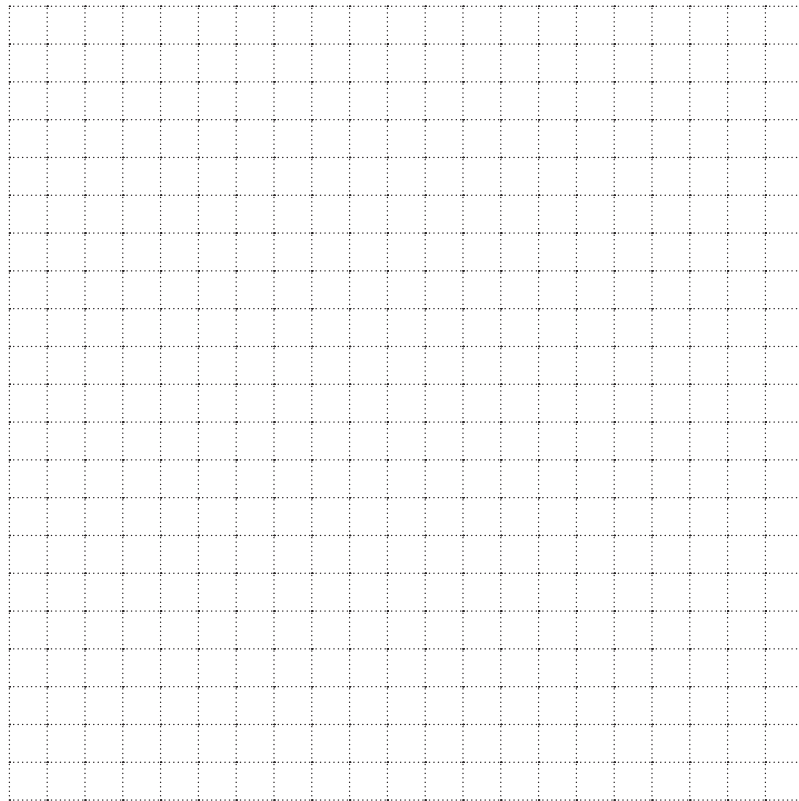
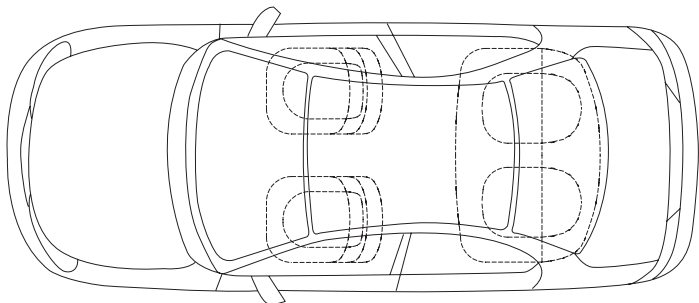

## Warranty obligations

Manufacturer guarantees correct operation of the service-security system if exploitation, installation, storage and transportation conditions described in this manual were met.

The system should only be used according to installation scheme and user manuals.

The system is meant to be installed by the professional car electronics installers. We recognize that outside Russia the system can be installed by amateurs – those installations are still a subject of limited warranty. The installer should fill in installation certificate that is included in this manual.

Parts malfunctioning during warranty period on the fault of the manufacturer should be repaired or replaced by the installation center of the manufacturer or by certified service center. List of certified service centers outside Russia can be found on pandorainfo.com

The user loses the right for warranty services in the following cases:

- when warranty period expires;
- if exploitation, installation, storage or transportation conditions were not met;
- if there is mechanical damage of the external parts of the system after it is sold. This includes: fire damage, consequential damage in case of car accident, aggressive liquids and water seeping damage, damage caused by improper use;
  - if the damage was caused with incorrect settings and parameter adjustment;
  - if system devices are replaced with any devices that are not recommended by the manufacturer;
  - if manufacturer sealing is broken;
  - if there is no properly filled warranty card and installation certificate.

Warranty period is 3 years since the moment of purchase, but no more than 3,5 (three and a half) years since the moment of production.

This warranty does not include batteries of the remotes, as they have their own service life time.

Maintenances and repairs of the system with expired warranty period are carried out at the expense of the user on a separate contract between the user and the installer/service center.

## Transportation rules

Products should be transported in the original packaging by any means of transport as long as they are protected from mechanical damage and precipitation.

Packaged products should be stored on racks in piles of 6 or less boxes, in enclosed, dry, heated rooms (no less than 1m from heating) which exclude possible interaction with moisture, oil products and damaging environmental factors.

## Installation certificate

I, the undersigned \_\_\_\_\_  
Position, name

professional installer, certify that installation of the service-security system, specified below, was carried out by me in accordance with manuals and schemes provided by the manufacturer.

### Car specifications:

Car model \_\_\_\_\_

Type \_\_\_\_\_

ID number (VIN) \_\_\_\_\_

Registration number \_\_\_\_\_

### Security system specifications:

Model Pandora DXL-1820L/1830L

Serial number \_\_\_\_\_

Service center name, full address and installer's stamp \_\_\_\_\_  
\_\_\_\_\_  
\_\_\_\_\_

Signature \_\_\_\_\_/\_\_\_\_\_

Signator

Work accepted \_\_\_\_\_/\_\_\_\_\_

Signator

Date « \_\_\_\_ » \_\_\_\_\_ 20\_\_y

## Acceptance certificate

Pandora DXL-1820L/1830L is in conformity with Electromagnetic Compatibility Directive EMC 2004/108/EC and R&TTE Directive 1999/5/EC

Serial number \_\_\_\_\_

Date of production \_\_\_\_\_

Responsible person's signature

(stamp)

Packager \_\_\_\_\_

Signature (personal stamp)

---

## Warranty card

Model Pandora DXL-1820L/1830L

Serial number \_\_\_\_\_

Date of purchase « \_\_\_\_ » \_\_\_\_\_ 20\_\_y

\_\_\_\_\_  
Seller's (installer's) stamp

\_\_\_\_\_  
Seller's signature \_\_\_\_\_