

Pandora would like to thank you for choosing our DXL 1920/1930 service and security system

Pandora DXL 1920L/1930L – is a premium car service-security system, built for cars with on-board voltage of 12V. It is a complex engineering solution which includes car security system, telemetry, remote and automatic engine start and various service options, all controlled from your OEM key remote, smartphone or online service.

When building **Pandora DXL 1920L/1930L** we were using the most up-to-date electronics from world's best manufacturers. The device is built using high-precision mounting and control machinery, thus we guarantee highest possible quality, reliability and stable technical characteristics for the whole operation period. **Pandora DXL 1920L/1930L** has a cryptographically strong authorization code with unique dialog algorithm and individual 128 bit encryption key on every device. We guarantee 100% protection from electronic hacking for the whole operation period.

The system is built for your convenience: it's ergonomic, reliable, has the highest security and service characteristics, 3 years unconditional warranty and free service and support on the territory of Russian Federation and nearest states. We are happy to provide any support we can – feel free to use our online support.



WARNING! IT IS STRONGLY ADVISED TO HAVE PROFESSIONAL CAR MECHANIC INSTALLING THE SYSTEM. ANY CAR ELECTRONICS INSTALLER SHOULD BE ABLE TO INSTALL PANDORA DXL 1920L/1930L USING INSTALLATION SCHEME IN THIS MANUAL AND ALARMSTUDIO SOFTWARE. MOST FEATURES ARE HIGHLY DEPENDENT ON COMPETENT INSTALLATION. OUR SYSTEMS ARE THOROUGHLY TESTED FOR QUALITY, SO IF A FEATURE FAILS TO PRODUCE EXPECTED RESULTS, MOST LIKELY THE PROBLEM IS IN IMPROPER INSTALLATION

This device has limited external factors resistance. It should not be subjected to water beyond occasional splatter, or operated in temperatures outside -40 to +80° C range

IMPORTANT! Note that this manual describes remote and manual functions for the most part. Functionality of the system is vast and would require a book-sized manual to fully describe. Instead we use handy software named AlarmStudio that functions as both programming tool and an extended installation & functionality manual. It requires Windows and can be downloaded at pandorainfo.com

Our web site: www.pandorainfo.com
Customer support: support@pandorainfo.com



Product is in conformity with Electromagnetic Compatibility Directive EMC 2004/108/EC and R&TTE Directive 1999/5/EC

Table of contents

System features	4
Car security zones	4
System set	5
Siren sounds and turn light signals	6
Meaning of indicator LED colors	6
Checking the number of recorded radio tags/mobile device	6
Control over the system	7
Arming/disarming using radio tag	7
Arming/disarming in Hands Free mode	7
Arming/disarming in «Slave» mode	7
Immobilizer mode	8
Anti-Hi-jack mode	8
Code immobilizer using original car controls	9
Replacing immobilizer tag battery	9
Control over the system in case of emergency	9
Emergency disarming using «VALET» button	10
Enabling/Disabling immobilizer radio tag	11
Control over the system via a phone	12
DTMF – commands	12
Changing core settings via phone	15
Installation and configuration of the system	17
General installation requirements	17
Wiring description	18
Wiring diagram	20
Programming the systems	23
Preparing to program the system using a computer	24
Updating firmware	25
Programming using VALET button	25
Online service and mobile application	32

Additional devices	36
---------------------------	-----------

Information	38
Warranty obligations	38
Installation certificate	39
Acceptance certificate	40
Warranty card	40

System features

Base unit

- Android and iOS applications.
- Individual PIN-code to disarm and switch off immobilizer.
- Hands Free mode for arming/disarming.
- Anti-hi-jack mode.
- Automatic arming
- Validator mode
- Algorithms of original immobilizer bypass.
- Integrated GSM-interface.
- Integrated GPS/GLONASS-receiver.
- Built-in 2,4 GHz module with support of Bluetooth 4.2 Low Energy protocol.
- Dialog coding of control commands.
- Individual 128-bit encryption key.
- Built-in integral accelerometer for determining motion and shocks with adaptive processing algorithm and sensitivity controls.
- Advanced process of sensor data reading, eliminating false alarm possibilities
- Built-in temperature sensor.
- Firmware updates via built-in micro-USB socket.

Bluetooth tag

- Dialog coding of control commands
- Individual 128-bit encryption key
- Built-in LED indicator.
- Built-in button to control over security modes.
- Built-in integral accelerometer.

Car security zones

Pandora DXL 1920L/1930L service-security system guards following independent zones:

- car doors perimeter
- front hood triggers
- trunk triggers
- ignition trigger
- brake pedal pressing
- triggering of the built-in shock sensor (warning level)

- triggering of the built-in shock sensor (alarm level)
- triggering of the built-in motion sensor
- triggering of the built-in tilt sensor
- critically low on-board voltage
- marker lights left on notification when arming*.

System set

Base unit	1
Bluetooth tag	2
Leather case for tags	1
Cable with VALET button and three-colored light indicator	1
User installation manual	1
Plastic card with individual secret code	1
Temperature sensor	1
Relay module	1
Main cable	1
IMMO-interface cable	1
Fastening kit	1
Packaging	1

Manufacturer reserves the right to change set and construction of the product to improve its technological and operational parameters without notification.

* - Availability of this function depends on car make and model

Siren sounds and turn light signals

Signal name	Signal description
Alarm mode, PANIC mode	Incessant sound and light signals for 30 sec
Arming	1 sound and 1 light signals
Disarming	2 sound and 2 light signals
“Sensors triggered” signal when disarming	4 sound and 4 light signals
“Sensor malfunction” signal when arming	4 sound and 4 light signals
Sensor warning level triggered	3 sound signals
Car search	5 sound and 5 light signals

Meaning of indicator LED colors

Indicator status	Meaning
Short red flashes	The system is armed
Lit red	The system is preparing for automatic arming
Orange flash	Confirms VALET button press
Green flashes	Confirms a number of recorded remotes (when switching on ignition)
Red flash	Confirms a recorded mobile device (when switching on ignition)
Red and green flashes	PIN-code confirmed
Faded	The system is disarmed

Checking the number of registered radio tags/mobile devices

The number of recorded tags and registered mobile device can be checked by the number of green and red flashes of LED indicator. Number of registered tags can be checked every time the ignition is switched on when the system is disarmed. Number of green **LED** flashes will indicate the number of recorded tags, following red flash will indicate registered mobile device.

You can also check the number of recorded tags and registered mobile device by taking off and putting back on battery terminal. The system will emit short sound signals from a siren with less than 1 sec. interval. The number of the signals equals to the number of recorded tags. After a pause of 2 seconds the system signal will indicate registered mobile device.

CONTROL OVER THE SYSTEM

Arming/disarming using radio tag

To arm/disarm the system, RF tag should be in radio coverage area. The system produces a protected (AES-128 encryption) interactive high-speed exchange of authorization codes in the frequency range 2,4 GHz on one of 125 channels. To arm the system when the ignition is switched off, shortly press the tag button. The system will confirm the command receiving with 1 short sound signal and 1 flash of turn indicators. To disarm the system, shortly press the tag button. The system will confirm the command receiving with 2 short sound signals and 2 flashes of turn indicators. Each button press will be confirmed with **LED** indicator flash of the tag that indicates the battery is functioning correctly. If **LED** indicator does not flash or constantly lights, the tag battery should be replaced (see “Replacing immobilizer tag battery” section).



Arming/disarming in Hands Free mode

The system allows for programmable Hands Free arming and disarming. To arm the system, when the engine is not running, move with the remote tag away from the car at a distance greater than the regular radio coverage (10 meters for 2,4 GHz) – the system will be armed automatically. To disarm the system, move toward the car with remote tag. Enabling/disabling this function can be performed with a phone (see “Control over system via a phone” section).

Arming/disarming in «Slave» mode

In this mode it is possible to monitor the status of original security system of the car via CAN-bus or by analog inputs. When arming and disarming original security system, Pandora will be armed and disarmed respectively. The presence of a tag in the radio zone is not required, but at the beginning of motion if the tag is not detected by the system, the engine will be blocked.

There is an option in the system settings named "Prohibit disarming when the tag is absent". When this option is enabled, disarming procedure will be performed only if there is a tag in the radio zone.

Immobilizer mode

This mode is enabled by default. Use a phone to disable this mode (see "Control over system via a phone" section). When switching on the ignition, the base unit of Pandora security system performs a search for immobilizer tags in radio zone. If no radio tags were detected when the ignition is switched on, the system will block the engine with all radio relays that were programmed into the system. Engine blocking will only occur when motion sensor detects movement of the car. If additional analogue blocking relays were installed, they will block the engine immediately, before or when the car starts moving, it depends on system settings.

Anti-Hi-Jack mode

This mode is disabled by default. Use a phone to enable this mode (see "Change settings via a phone" section). Anti-hi-jack mode helps to prevent aggressive seizure of the car using delayed engine blocking on door opening.

Every time on opening/closing a door when the ignition is switched on, immobilizer requests response from a radio tag using unique algorithm. After a door was opened while the engine is running, if the system cannot detect a radio tag, the engine will be stopped after 1 minute (general safety requirement). A siren will play "ENGINE BLOCKING WARNING" ringtone before blocking.

If engine blocking is performed via radio relay after warning signals are over or on new attempts to start the engine, immobilizer will only allow the engine to start when the car is not moving, and will block it again if it starts movement.

If the car starts moving, the immobilizer will block the engine for 15 seconds. When registered tag appears in the radio zone, blocking will be canceled and the system will return to the normal operation.

If the engine is blocked via analog relay, engine operation will be stopped after warning signals are over, until a registered tag appears in the radio zone or on registering movement – depending on the settings.

Code immobilizer using original car controls

Code immobilizer (validator) is a function that allows disarming, disabling blocking and controlling timer channels using original car controls (button, lever or pedal). To enter immobilizer code, programmed button (lever, pedal) should be pressed a number of times equals to the first digit of the code. Pauses between presses should not exceed 1 second. Pauses more than 1 second will be interpreted as the start of next digit input. Immobilizer code can consist max of 4 digits from 1 to 9.

After entering a correct immobilizer code, depending on the settings, either the engine blocking will be lifted or a programmed timer channel will be activated or the system will be disarmed.

Replacing immobilizer tag battery

Carefully open the cover of the tag's battery compartment. Extract discharged battery and insert a new one keeping in mind the correct polarity. Replacing a battery will not cause a loss of tag code information, as authorization data is stored in the non-volatile memory of the MCU. Carefully close the cover of the tag's battery compartment. All elements of construction should be rigidly locked in places. If it is so, the tag can be operated as usually.

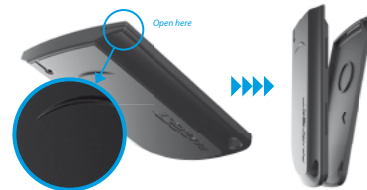

Control over the system in case of emergency

Use a phone to deactivate the system quickly. To disarm the system via a phone, call the system's number. When it answers, dial command **0***. If the call is not made from the owner's number, guest PIN-code should be entered. Factory set guest PIN-code is **1-2-3-4**.

To switch off an immobilizer tag, dial the **998*** command (after dialing, enter the "Secret PIN-code" that is located on the owner's plastic card). To switch on an immobilizer tag, dial the **888*** command.

If the system cannot be deactivated via a phone, apply emergency disarming and switching on/off an immobilizer tag using **VALET** button.



WARNING!
ANTI-HI-JACK MODE IS NOT LEGAL IN SOME COUNTRIES.

Emergency disarming using «VALET» button



WARNING! MAKE SURE THAT A PROTECTIVE LAYER ON THE OWNER'S PLASTIC CARD IS INTACT AFTER THE INSTALLATION OF THE SYSTEM. THE PLASTIC CARD HOLDS THE "SECRET PIN-CODE".



WARNING! CAREFULLY REMOVE THE PROTECTIVE LAYER, DO NOT USE SHARP OBJECTS TO AVOID DAMAGING OF HIDDEN INFORMATION UNDER A PROTECTIVE LAYER.

In case you cannot disarm the system using a phone or immobilizer tag, the "Secret PIN-code" can be used. The "Secret PIN-code" is written on the owner's plastic card under protective layer. Erase the protective layer and use **VALET** button to input the PIN-code.

The code must be entered only when the base unit is powered and the ignition is switched off. The PIN-code can be entered using external or located on the base unit **VALET** button. The digits input and correct input is indicated by the external or located on the base unit **LED** indicator.

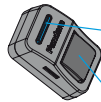
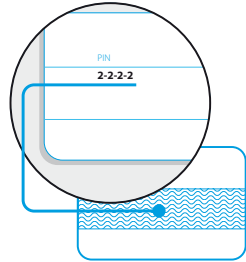

Three-color status LED indicator (green, red, orange)

VALET button

Entering the PIN-code:

Enter the first digit of the code using **VALET** button. Press the button a number of times, equals to the first digit. Pauses between presses should not exceed 1 second. Each pressing will be confirmed with an orange **LED** indicator flash. A Pause for more than 1 second and a red **LED** indicator flash confirm the input of the first digit. Then you can enter the next digit.

• Enter the second digit of the code using **VALET** button. Press the button a number of times, equals to the second digit. Pauses between presses should not exceed 1 second. Each pressing will be confirmed with an orange **LED** indicator flash. A Pause for more than 1 second and a red **LED** indicator flash confirm the input of the second digit. Then you can enter the next digit.

• Enter the third digit of the code using **VALET** button. Press the button a number of times, equals to the third digit. Pauses between presses should not exceed 1 second. Each pressing will be confirmed with an orange **LED** indicator flash. A Pause for more than 1 second and a red **LED** indicator flash confirm the input of the third digit. Then you can enter the next digit.

• Enter the fourth digit of the code using **VALET** button. Press the button a number of times, equals to the fourth digit. Pauses between presses should not exceed 1 second. Each pressing will be confirmed with an orange **LED** indicator flash. The system will confirm correct PIN-code with the series of red and green flashes and the system will be disarmed. If the input was incorrect, it will be indicated with a red **LED** indicator flash and the system will stay in a previous state. New input can be attempted after 5 seconds.

If the system was disarmed and the ignition was switched off it will enter programming mode after correct input of the PIN-code.

For emergency arming when the ignition is switched off, press and hold **VALET** button for 3 seconds. The system will be armed in 30 seconds. Status **LED** indicator is lighting red during the countdown.

Enabling/Disabling immobilizer radio tag



WARNING!
IT IS HIGHLY RECOMMENDED TO CHANGE FACTORY PRESET OF THE "SERVICE PIN-CODE" FOR IMPROVING SECURITY OF THE SYSTEM.



Write down or remember the "Service PIN-code"

To disable immobilizer radio tag, enter level 15 (the system should be in programming mode). Enter the "Secret PIN-code" to disable radio tag or press **VALET** button once to enable radio tag.

Enter the "Service PIN-code" to enter programming mode (factory preset of the service PIN-code is "1-1-1-1"). You can enter the code only if the base unit is powered, the ignition is switched off, the system is disarmed and the maintenance mode is switched off. If there is no "Service PIN-code", you can enter programming mode using the "Secret PIN-code" written on the owner's card. After entering programming mode, press **VALET** button 15 times. Green color of **LED** indicator means a radio tag is switched on, red color means a radio tag is switched off.

Disabling radio tag:

LED indicator will light green after entering the programming level. The system will wait for entering the "Secret PIN-code". Enter the "Secret PIN-code" that is written on the owner's plastic card. The system will confirm disabling of the radio tag with two sound signals of the siren and a long red **LED** flash. After that the system will return to the programming menu. If the PIN-code is not entered within 10 seconds or the input is incorrect, a siren will sound one signal, **LED** will produce the series of red and green flashes and the system will return to the programming menu.

Enabling radio tag:

LED indicator will light red after entering the programming level. The system will wait for action. Press **VALET** button once to enable radio tag. The system will confirm enabling with one short sound signal of a siren and a green **LED** light. After that the system will return to the programming menu.

CONTROL OVER THE SYSTEM VIA A PHONE



WARNING! IF THE CALL IS NOT MADE FROM THE OWNER'S NUMBER, GUEST PIN-CODE SHOULD BE ENTERED. FACTORY SET GUEST PIN CODE IS 1-2-3-4. AFTER THE SYSTEM IS INSTALLED, PLEASE CHANGE FACTORY SET PIN-CODE. 1-2-3-4.

DTMF – commands

For example: To have simple access to engine start function, create a new contact in the contact list of your phone, name it "Engine start", for instance, and add the number in the following format: **+XXXXXXXXXXXX,123*,297***

where "+XXXXXXXXXXXX" – the system phone number,
"- pause is a feature of the phone (can be displayed as the "P", see the instructions of the phone),
"123*" – remote engine start DTMF command,
"297*" – end call DTMF command.

#	Return to previous menu state	6 6 6 *	Enable engine blocking
*	Repeat the last message	9 9 9 *	Disable engine blocking
1 *	Arming	2 5 8 *	System information
0 *	Disarming	9 9 8 *	Disable immobilizer tag
1 0 *	Silent arming	8 8 8 *	Enable immobilizer tag
0 0 *	Silent disarming	2 2 2 *	Disable Hands Free mode
9 *	Help	2 2 3 *	Enable Hands Free arming
0 9 *	Event history	2 2 4 *	Enable Hands Free disarming
1 5 *	Tow truck mode	2 2 5 *	Enable Hands Free disarming only with autom. start
1 0 0 *	Request GSM account balance	7 8 9 *	Enable automatic engine start
1 2 3 *	Start the engine/prolong heating	9 8 7 *	Disable automatic engine start
3 2 1 *	Stop the engine	2 9 7 *	Call ended
3 3 3 *	Switch on add. function using F via CAN	5 5 1 *	Enable maintenance mode (see description below)
5 0 0 *	Request current coordinates	5 5 2 *	Disable maintenance mode
4 5 6 *	Switch on additional channel	1 5 6 *	Switch on engine preheater
6 5 4 *	Switch off additional channel	6 5 1 *	Switch off engine preheater

Contact can be added as a speed dial to any of the free button.

To have simple access to engine start function a phone other than the main owner's phone, create contact in the following format:

+XXXXXXXXXXXX,1234,123*,297*

where "1234" – guest PIN-code.

Enable/Disable maintenance mode

1. Call the system number. Wait for answer.
2. To enable maintenance mode, dial "Enable maintenance mode" DTMF command **551*** (the ignition should be switched on, radio tag should be in range if immobilizer/Anti-Hi-jack mode is active)
3. Enter the "Secret PIN-code" that is located on the owner's plastic card.
4. To disable maintenance mode, dial **552*** DTMF command.

Voice help

The system has voice help menu. During voice call to the system, dial **9*** and listen to the information about system control commands. To end session, hang up the phone.

Repeat the last message

To repeat any message, press* during a voice call to the system

Arming/disarming

1. Call the system number. Wait for answer.
 2. Dial **1*** to arm, and **0*** to disarm
- For silent arming dial **10*** or **00*** for silent disarming
3. The system will confirm arming/disarming.



WARNING!
ENABLE REMOTE START ONLY IF YOUR LOCAL LEGISLATION ALLOWS DRIVERLESS CARS TO HAVE WORKING ENGINE.

Enabling/disabling automatic engine start

Pandora system has function of promptly disabling automatic engine start.

1. Call the system number. Wait for answer.
 2. Dial **987*** to disable all automatic engine starts or **789*** to enable all automatic engine starts.
 3. The system will confirm execution
- To end session, hung up the phone

Automatics starts can be enabled again by dialing **789*** (all previous settings will remain intact)

Blocking/unblocking the engine

You can block car's engine using any phone. The engine will remain blocked until phone command "Disable engine blocking" will be sent. This blocking cannot be disabled using a tag.

1. Call the system number. Wait for answer.
2. Dial **666*** to enable engine blocking or **999*** to disable engine blocking (after dialing **999***, you will need to enter the "Secret PIN-code" that is located on the owner's plastic card).



WARNING! DISABLING OF THE ENGINE BLOCKING THAT WAS ENABLED VIA A PHONE 666* IS ALLOWED ONLY BY DIALING 999* AND ENTERING THE "SECRET PIN-CODE".

Request current coordinates

1. Call the system number. Wait for answer.
2. Dial **500***.
3. The system will confirm: "Current coordinate sent via text message" and will send text message with coordinates and a web link to a map to your phone.

To end session, hang up the phone.

Request GSM account balance

1. Call the system number. Wait for answer.
2. Dial **100***.
3. The system will confirm: "Balance information sent via text message" and will send text message with account balance information to your phone.

To end session, hang up the phone.

Tow truck mode

This mode is intended for car transportation with preservation of arming function. Tow truck mode can be activated only when the system is armed, it will be deactivated automatically when disarming.

1. Call the system number. If the system is in PANIC mode, receive emergency call. Wait for answer.
2. Dial **15*** to enable Tow truck mode, the system will disable motion, shock and tilt sensors.
3. To disable this mode, disarm the system.

To end session, hang up the phone.

Similarly any other system command can be entered.

Changing core settings via phone

To enter settings programming mode:

1. Disarm the system
2. Call the system number. Wait for answer.
3. Switch ignition on for 1-3 seconds, then switch it off.

The system will enter settings programming mode.

Example of changing the owner's system number:

1. Enter the setting menu via a phone according to the instruction above;
2. Dial DTMF command **1***(phone number settings) and **1***(owner's system number);
3. Enter new owner's number in the format ***XXXXXXXXXXXX #** (the system recognizes "*" as "+");
4. To confirm, dial **1***



WARNING!
THERE ARE ONLY TWO WAYS TO CHANGE THE OWNER'S PHONE NUMBER:
1. VIA A PHONE, USING CORE SETTINGS MENU.
2. VIA A COMPUTER AND PANDORA ALARMSTUDIO SOFTWARE

1 * *	1 * *	Owner's number -> #
	2 * *	Additional owner's number -> #
	3 * *	Second additional owner's number -> #
	4 * *	Account balance inquiry number -> #
	5 * *	System's number -> «#»

2 * *	1 * *	Voice calls on alarm
	2 * *	Voice calls on triggering warning level of the sensors
	3 * *	Voice calls on engine start
	4 * *	Voice calls on engine stop
	5 * *	Voice calls on restoring GSM connection
	6 * *	Voice calls on disarming
	7 * *	Voice calls on entering programming mode
	8 * *	Voice calls when radio relay connection is lost
	9 * *	Voice calls when on-board voltage is low
	0 * *	Voice calls on accident

3 * *	1 * *	Text messages on alarm
	2 * *	Text messages on triggering warning level of the sensors
	3 * *	Text messages on engine start
	4 * *	Text messages on engine stop
	5 * *	Text messages on restoring GSM connection
	6 * *	Text messages on disarming
	7 * *	Text messages on entering programming mode
	8 * *	Text messages when radio relay connection is lost
	9 * *	Text messages when on-board voltage is low
	0 * *	Text messages on accident

4 * *	1 * *	Immobilizer (on/off)
	2 * *	AntiHijack

5 * *	1 * *	Changing guest PIN-code
	2 * *	Entering as guest
	3 * *	Remote blocking
	5 * *	Set threshold voltage for sending text message

6 * *	1 * *	By time
	2 * *	Set up time for automatic start
	3 * *	By voltage
	4 * *	Set up voltage for automatic start
	5 * *	By temperature
	6 * *	Set up temperature for automatic start
	7 * *	By period
	8 * *	Set up period for automatic start

7 * *	1 * *	Settings of the warning level of the shock sensor sensitivity
	2 * *	Settings of the alarm level of the shock sensor sensitivity
	3 * *	Settings of the motion sensor sensitivity
	4 * *	Settings of the tilt sensor sensitivity
	5 * *	Settings of the warning level of the supplementary sensor sensitivity
	6 * *	Settings of the alarm level of the supplementary sensor sensitivity

8 * *	1 * *	GSM connection
	2 * *	Money saving mode of the GSM connection
	3 * *	Voice calls in roaming service

9 * *	1 * *	Set up date
	2 * *	Set up time

NOTE: Engine start via temperature is available only if temperature sensor is connected. The sensor availability depends on the system set.

INSTALLATION AND CONFIGURATION OF THE SYSTEM

General installation requirements

- Only install base unit inside car interior.
- Install securely each system's component, as conditions of the car standard operation can harm functionality of the alarm system and cause damage to the car original systems, including the elements of safety in motion.
- The system installation should be performed when the system sockets and the negative battery terminal are disconnected.
- The base unit power supply should be switched off when connecting to CAN-bus.
- The system installation can be performed via twisting together or via lead-tin soldering followed by isolation of a switching place.
- When wiring, pay attention to sections and materials of switched conductors, if they are different, bring electrochemical potentials to the minimal difference. The isolation should not allow for moisture to reach wiring, as the presence of moisture will increase electrochemical destruction of wires (this is especially important for the large current circuits).
- Switched connections should be placed as high as it is possible in the cavities so water condensate will not form drops on the switching location.
- To avoid the destruction of compounds by car vibration, ensure that there is a bit of free length to the wiring, providing enough sagging.
- Do not allow wiring in places where the wires isolation can be destroyed by abrasion.
- Electronic system units should be placed sockets down and as high as possible to avoid condensate reaching electronic components through the socket.
- When installing base unit, secure it to the car body for correct operation of in-built shock sensor.
- All unused system wires during the installation must be insulated and secured to prevent accidental touching of a car body or other wires.

Wiring description

X5 Socket (main socket):

- **Wire «1» (White) (Tachometer input)** — analog input of the tachometer signal, it connects to the tachometer wire or to the signal wire of a nozzle, which provide stable pulses of any polarity corresponding to the RPM.

- **Wire «2» (Red-black) (CH5)** Factory setting is “Beeper”. A negative output of additional channel with maximum load current 200mA. This output is multipurpose, it can operate in accordance with selected logic.

- **Wire «3» (Orange-white) (CAN1-High)** It connects to appropriate CAN-High wire of the car.

- **Wire «4» (Yellow-white) (CAN2-High)** It connects to appropriate CAN2-High wire of the car.

- **Wire «5» (Gray) (CH1/INP1)** – Factory setting is Door trigger. This wire connects to a wire that becomes grounded when the door opens. This wire is multipurpose, it can operate as input and as output in accordance with selected logic.

- **Wire «6» (Green) (CH4/INP4)** Factory setting is “Control turn indicators”. This wire connects to the hazard flashers button. A negative output of additional channel with maximum load current 200mA. This output is multipurpose, it can operate in accordance with selected logic.

- **Wire «7» (White-Blue) (INP5)** Factory setting is “Brake pedal”. This wire connects to the brake pedal trigger where 12V voltage appears when the pedal is pressed (stop lights wire). Brake pedal signal is one of the system’s security zones. This input is multipurpose, it can operate in accordance with selected logic.

- **Wire «8» (Black) (Ground)** It should be connected to the car body in a grounding spot. This wire should be connected FIRST during installation.

- **Wire «9» (Blue) (CH2)** Factory setting is free output. A negative output of additional channel with maximum load current 200mA. This output is multipurpose, it can operate in accordance with selected logic.

- **Wire «10» (Brown-White) (INP3)** Factory setting is “Front hood and trunk trigger”. This wire connects to appropriate wire that becomes grounded when the front hood opens. This input is multipurpose, it can operate in accordance with selected logic.

- **Wire «11» (Orange-black) (CAN1-Low)** It connects to appropriate CAN-Low wire of the car.

- **Wire «12» (Yellow-black) (CAN2-Low)** It connects to appropriate CAN2-Low wire of the car.

- **Wire «13» (Blue-Black) (CH3)** Factory setting is “Blocking N.O.”. This output is used to control blocking relay with a normally open logic (it becomes grounded when switching on the ignition and security system is not armed). A negative output of additional channel with maximum load current 200mA. This output is multipurpose, it can operate in accordance with selected logic.

- **Wire «14» (Yellow) (INP2)** — Factory setting is “Ignition”. This wire connects to ignition switch or to appropriate wire where 12V voltage appears when ignition is switched on. This input is multipurpose, it can operate in accordance with selected logic.

- **Wire «15» (Purple) (Siren)** It connects to siren control wire (+) (maximum load current is 2A).

- **Wire «16» (Red) Power Supply +12V)** It should be connected to reliable conductor with constant voltage of 12V.

X6 Socket (Relay module):

- **Wire «1» (Blue) (CH6)** Factory setting is “Blocking N.O.”. This output is used to control blocking relay with a normally open logic (it becomes grounded when switching on the ignition and security system is not armed). A negative output of additional channel with maximum load current 200mA. This output is multipurpose, it can operate in accordance with selected logic.

- **Wire «2» (Orange) (CH7)** Factory setting is “ACC”. The channel is used to control accessories. If “Car with START/STOP button” setting is enabled, the channel will control brake pedal during remote or automatic engine start. A negative output of additional channel with maximum load current 200mA. This output is multipurpose, it can operate as input or output in accordance with selected logic.

- **Wire «3» (Brown) (CH8)** Factory setting is “Ignition”. This output is used to switch on ignition. It allows implementing automatic engine start, turbo timer, ignition support and connecting to ignition in series (incut). If “Car with START/STOP button” setting is enabled, the channel will operate in impulse mode to control the button. A negative output of additional channel with maximum load current 200mA. This output is multipurpose, it can operate as input or output in accordance with selected logic.

Pandora DXL 1920L/1930L

For remote engine start

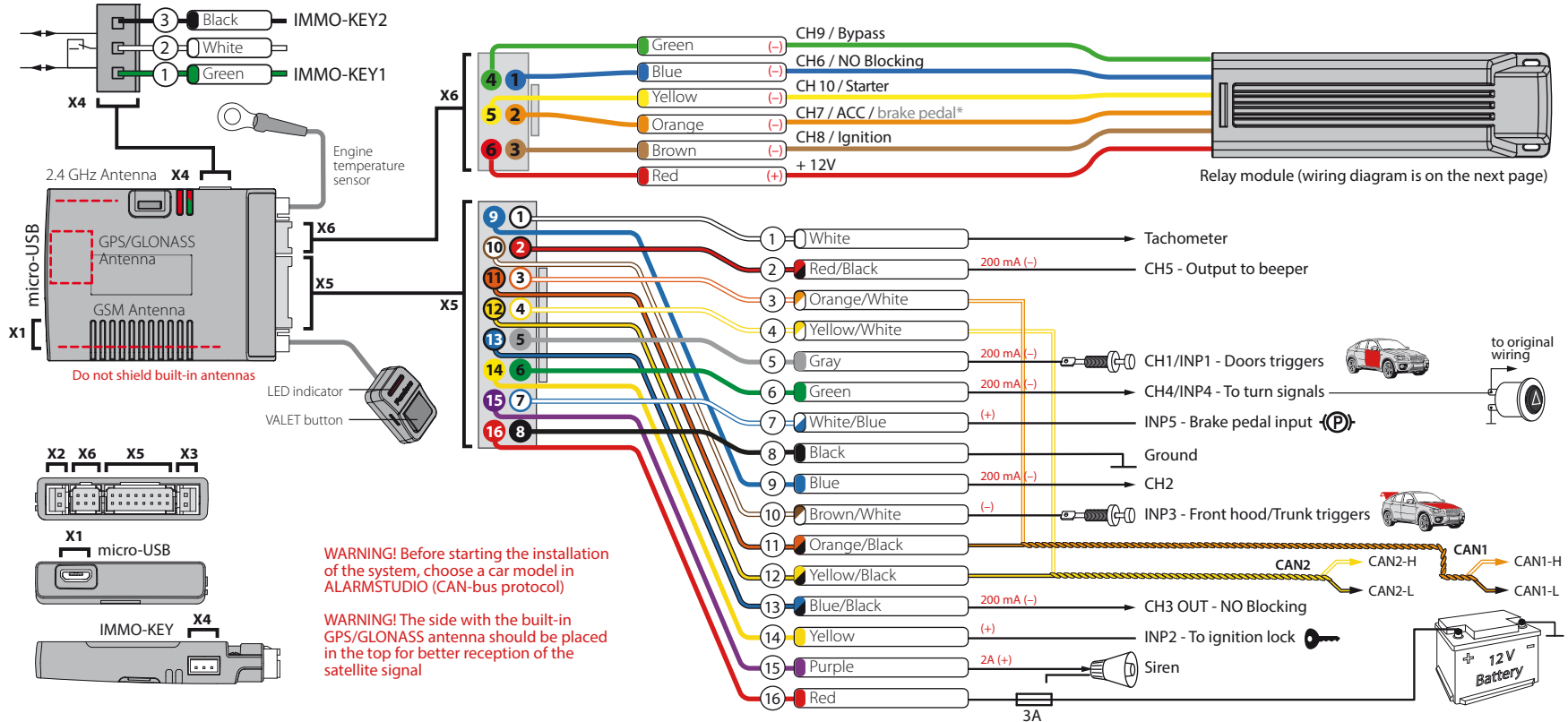

Pandora

RMD-5M Relay Module

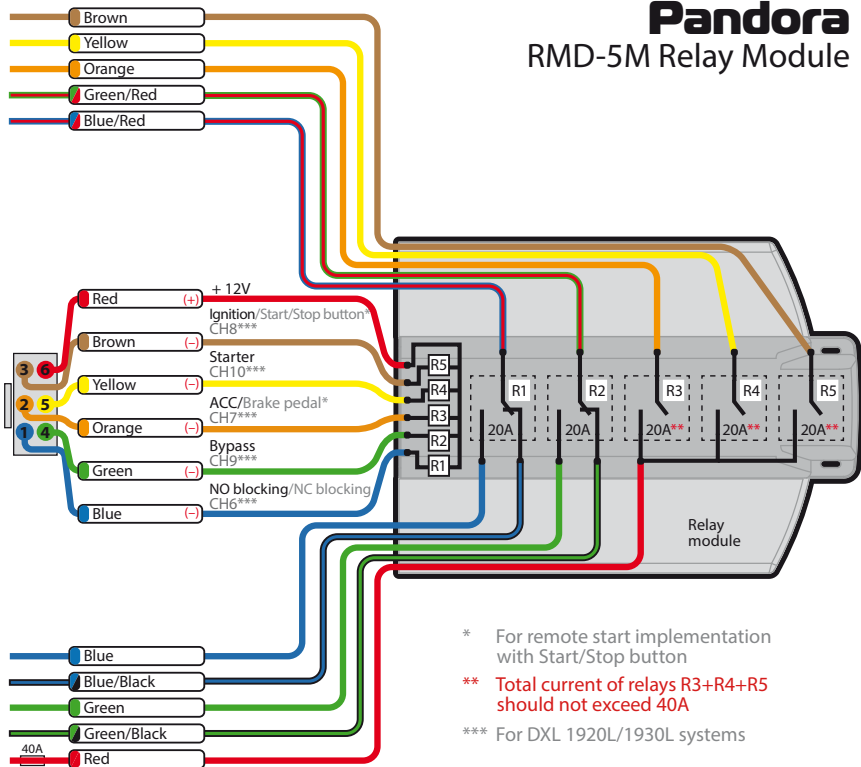

* For remote start implementation with Start/Stop button

** Total current of relays R3+R4+R5 should not exceed 40A

*** For DXL 1920L/1930L systems

- **Wire «4» (Green) (CH9)** Factory setting is “Bypass”. Output activates during remote or automatic engine start. A negative output of additional channel with maximum load current 200mA. This output is multipurpose, it can operate as input or output in accordance with selected logic

- **Wire «5» (Yellow) (CH10)** Factory setting is “Starter”. This output is used to switch on starter of the car. A negative output of additional channel with maximum load capacity 200mA. This output is multipurpose, it can operate as input or output in accordance with selected logic.

- **Wire «6» (Red)** — relay module power supply 12V.

X7 Socket (Multifunction channels)

Use this socket when implementing bypass of original immobilizer using IMMO-KEY1 and IMMO-KEY2 multifunctional channels. Make connections in accordance with installation scheme. The settings of the socket are available in AlarmStudio. Disconnect the system from power supply after changing the settings.

PROGRAMMING THE SYSTEM

Entering programming menu

To change the system settings or program the system using a computer or **VALET** button, the system should be in programming mode. Enter programming mode by entering “Service PIN-code” (factory preset is 1-1-1-1). PIN-code should be entered using external or located on the base unit **VALET** button. The input is indicated by flashes of external or located on the base unit **LED** indicator. You can enter the code only if the base unit is powered from USB socket or from external power supply, the ignition is switched off, the system is disarmed and maintenance mode is switched off.

If there is no “Service PIN-code”, you can enter programming mode using the “Secret PIN-code” written on the owner’s card.

Entering PIN-code:

- Enter the first digit of the code using **VALET** button. Press the button a number of times, equals to the first digit. Pauses between presses should not exceed 1 second. Each pressing will be confirmed with an orange **LED** indicator flash. A Pause for more than 1 second and a red **LED** indicator flash confirm the input of the first digit. Then you can enter the next digit.
- Enter the second digit of the code using **VALET** button. Press the button a number of times, equals to the second digit. Pauses between presses should not exceed 1 second. Each pressing will be confirmed with an orange **LED** indicator flash. A Pause for more than 1 second and a red

- **LED** indicator flash confirm the input of the second digit. Then you can enter the next digit.
- Enter the third digit of the code using **VALET** button. Press the button a number of times, equals to the third digit. Pauses between presses should not exceed 1 second. Each pressing will be confirmed with an orange **LED** indicator flash. A Pause for more than 1 second and a red **LED** indicator flash confirm the input of the third digit. Then you can enter the next digit.
- Enter the fourth digit of the code using **VALET** button. Press the button a number of times, equals to the fourth digit. Pauses between presses should not exceed 1 second. Each pressing will be confirmed with an orange **LED** indicator flash. The system will confirm correct PIN-code with the series of red and green flashes and the system will enter programming mode. If the input was incorrect, it will be indicated with a red **LED** indicator flash and the system will stay in a previous state. New input can be attempted after 5 seconds.

Exit programming mode:

To exit programming mode turn on the ignition or turn off power of the base unit. The system will reboot programmatically (all changes will be saved) after exiting programming mode using ignition. All ways to exit the programming menu are accompanied by sound signals of the siren and light signals of the LED indicator. Light signals indicate the number of recorded devices: first green flashes indicate the number of recorded radio tags, red flash indicates registered mobile device.

Status indicator lights during PIN-code entering:

Short orange flash	Confirmation of VALET button pressing
Short red flash	Confirmation of entering a PIN-code digit
Red and green flashes	PIN-code is correct
Long red flash	PIN-code is incorrect

Preparing to program the system using a computer

The system allows programming all settings and updating software of the base unit via micro-USB cable. If the base unit has not been installed in the vehicle yet, it will be powered via micro-USB cable while programming. To program using a computer, you need a standard USB cable, a computer with Windows XP/Vista/7/8/10 and Pandora AlarmStudio application (you can download it from pandorainfo.com).

It is required to create an account in AlarmStudio to use Pandora CLONE for remote engine start (you can register without a connection to a system). Pandora CLONE procedure requires Internet connection.

In preparation to the programming these stages should be followed:

- connect the system and PC via USB cable;
- start Pandora AlarmStudio;
- enter the programming settings mode by entering the service PIN-code.

Updating firmware

It is recommended to update firmware of the base unit before installing and programming the system (actual version of the firmware you can download from **pandorainfo.com**). You can update firmware using AlarmStudio application after entering programming mode or using quick boot algorithm (PIN-code is not required).

Quick boot mode: open AlarmStudio; de-energize and disconnect the system; press and hold **VALET** button located on the base unit; release the button immediately after connecting the system and a computer via USB cable; the system will enter boot mode.

If the boot mode has been interrupted for some reason and the status indicator lights red, you need to load firmware using quick boot mode (without entering PIN-code).

Programming using VALET button

The system allows programming some settings using **VALET** button. To configure all settings use a computer to program the system.

Enter programming mode by entering the "Service PIN-code", Use **VALET** button to enter the desired level number (press the button a number of times, equal to level number; pauses between presses should not exceed 1 second). The system will confirm correct input with red **LED** flashes and short sound signals of a siren and proceed to the desired level. If the input was incorrect, the system will not confirm input and will await a new level input after a series of green and red flashes

Level 1	Recording remotes and radio tags into the system memory
Level 2	Changing the factory preset of the service PIN-code
Level 3	Recording the idle speed to the system memory

Level 4	Resetting to factory settings
Level 5	Recording Bluetooth engine compartment module
Level 6, 7	Recording Bluetooth radio relays №1, №2
Level 8	Reserved
Level 9	Reserved
Level 10	Configuring system settings via the wireless interface
Level 11	Programming and configuring "Immobilizer code"
Level 12	Reserved
Level 13, 14	Reserved
Level 15	Emergency disabling of immobilizer radio tag
Level 16	Updating Bluetooth modem firmware
Level 17	Programming bypass of original immobilizer
Level 18	Registering and unregistering mobile device
Level 19, 20	Updating radio relays №1, №2 firmware

Level 1 – Recording remotes and radio tags into the system's memory

Prepare to record all radio tags (you can record up to 3 tags), install batteries in the radio tags.

Enter programming menu and then press **VALET** button once. **LED** indicator will light green and the system will enter the tag recording mode. Tags are recorded (paired) one by one, in any order and without time limit. All previously registered radio tags will be removed when you overwrite new tags or overwrite old tags.

Recording radio tags:

Press control button on a tag and hold it for 6 seconds (6 flashes of tag status indicator), release the button after the sixth flash. If the recording was successful, a siren will emit 1 beep, after that you can move to recording the next tag.

Saving changes:

To finish the recording of radio tags into the system, **VALET** button should be pressed once again, the series of red and green flashes of status **LED** indicator will confirm the saving.

Level 2 – Changing the factory preset of the service PIN-code

Prepare a new value of the "Service PIN-code", it should consist of 4 digits (from 1 to 9). Write down or remember the new PIN-code.

Enter programming menu and then press **VALET** button twice. The system will enter "Changing Service PIN-code" mode and the status **LED** indicator will turn off.

Changing the "Service PIN-code":

- Enter the first digit of the code using **VALET** button. Press the button a number of times, equals to the first digit. Pauses between presses should not exceed 1 second, every pressing will confirm with orange **LED** indicator flash. Pause for more than 1 second and red **LED** indicator confirms the input of the first digit. Then you can enter the next digit.
- Enter the other numbers in the same manner. The input of the fourth number will be confirmed by series of red and green **LED** indicator flashes. The system will wait for PIN-code re-entering.
- Enter all four digits again;
- If you were able to correctly enter the "Service PIN-code" twice, the indicator will produce the series of red and green flashes, new PIN-code will be recorded, the system will return to programming mode. In case of the incorrect code input the indicator will be lit red, the system will return to programming mode.

Level 3 – Recording the idle speed to the system memory

To timely turn off the starter during automatic or remote engine start via digital or analog tachometer input and the correct operation of the "Smart Turbo Timer", it is necessary to record the engine idle speed.

To record idle speed to the non-volatile system memory, enter the programming menu. Press **VALET** button three times. Switch on the ignition and start the engine after entering this level of programming (the engine should be warmed-up, idle speed should match the stable idle speed of the warmed-up engine). The system will confirm the presence of the idle speed status with green flashes of **LED** indicator. Wait until the stable idle speed will be reached and save the changes.

Saving changes:

Press **VALET** button once to save idle speed. Successful recording of the idle speed will be confirmed with the series of red and green flashes of **LED** indicator. The system will exit programming menu and reboot after saving the idle speed.

Level 4 – Resetting to factory settings.

The procedure recovers the factory settings of the system without deleting previously registered devices (tags, mobile device, relays, etc.) that is stored in the non-volatile memory.

To reset the settings enter the programming mode and press **VALET** button four times. Press and hold **VALET** button for more than 4 seconds until siren sound, then release the button. The system will

confirm the resetting to the factory settings with a long red flash of LED indicator. After that the system will return to a programming mode.

Level 5 – Recording Bluetooth engine compartment module

To record a Bluetooth engine compartment module, enter programming mode and press **VALET** button 5 times. The **LED** indicator will light green and the system will enter the recording of an engine compartment module mode. Connect the module in accordance with installation manual. The system will confirm the registration with a short sound signal.

Saving changes:

To finish the recording of the engine compartment module, **VALET** button should be pressed once again, the series of red and green flashes of the status **LED** will confirm the saving, switch on the ignition to automatically save the settings and exit programming mode.

Levels 6, 7 – Recording Bluetooth radio relays

Radio relays recording is performed one by one starting from the 6 level: radio relay №1 is recorded on the 6 level; radio relay №2 is recorded on the 7 level. The radio relay can be overwritten only on the level of its initial registration.

To record Bluetooth radio relays №1, №2, enter programming mode and press **VALET** button 6 times for radio relay №1 or 7 times for radio relay №2. **LED** indicator will light green and the system will enter the recording of a radio relay mode. Connect a relay in accordance with installation manual. The system will confirm recording with a short sound signal.

Saving changes:

To finish the recording of the Bluetooth radio relay, **VALET** button should be pressed once again, the series of red and green flashes of the status **LED** indicator will confirm the saving, switch on the ignition to automatically save the settings and exit the programming mode.

Level 10 – Configuring system settings via the wireless interface

This function is under construction.

Level 11 – Programming and configuring “Immobilizer code”

To program the “Immobilizer code”, enter the programming mode and press **VALET** button 11 times. The level is divided into 3 sublevels (Sublevel 11.1 – Selecting buttons; sublevel 11.2 entering PIN-code; sublevel 11.3 – confirmation of the PIN-code input).

The system will automatically enter the sublevel 11.1 (Selecting buttons) after entering the level 11. The system can determine buttons via analog “Code immobilizer” input or via digital protocol of a car. It is necessary to configure an analog input (INP) as “Code immobilizer” in the settings of the base unit inputs when implementing the “Code immobilizer” via an analog input. It may be necessary to switch on

the ignition after entering the level 11 of programming (if the car bus is active only when the ignition is switched on) when implementing the “Code immobilizer” via digital car bus protocol.

After selecting active buttons enter the sublevel 11.2 (Entering PIN-code) by pressing **VALET** button once. Program PIN-code using selected buttons at this sublevel; press **VALET** button once and enter PIN-code again. To confirm PIN-code re-entering and save all the settings press **VALET** button once again.

Sublevel 11.1 – Selecting buttons:

This sublevel is used to select active buttons via digital protocol of a car or via “Code Immobilizer” analog input. To determine the activity of the analog “Code Immobilizer” input, apply potential to the corresponding input (INP) of the base unit, **LED** indicator will be flashing orange.

If you determine buttons via digital protocol select one or more buttons (up to four) for entering the secret code of the immobilizer. To do this press the selected button, **LED** indicator will confirm input with orange flashes. If there are no orange flashes when any button is pressed, then this button is not recognized by the system, select a different button. Repeat the procedure to select the second, third, fourth button and enter the next sublevel. To enter the next sublevel press **VALET** button once.

Sublevel 11.2 – Entering PIN-code:

Program immobilizer deactivation PIN-code using selected button or buttons. Enter the first digit by pressing the previously selected button (pauses between presses should not exceed 1 second). The base unit will confirm entering with red flash of **LED** indicator. Enter the second (third, fourth) digit by pressing the previously selected button. The base unit will confirm entering of each digit with red flash of **LED** indicator.

Input the required number of digits (up to 4) and then press **VALET** button. The system will confirm receiving of the secret validator code with long red flash of **LED** indicator and will wait for confirmation of PIN-code.

Sublevel 11.3 – Confirmation of the PIN-code input:

Enter PIN-code again similarly to the procedure (level 11.2 – Entering PIN-code) and press **VALET** button. The system will confirm correct PIN-code with red and green flashes of **LED** indicator and will memorize PIN-code, and then the system will proceed to programming mode awaiting level input. Incorrect confirmation is indicated with long red flash of **LED** indicator, after that the system will return to programming mode.

Level 15 – Disabling/enabling immobilizer tag

To disabling/enabling of immobilizer tag, enter programming menu and press **VALET** button 15 times. **LED** indicator will light green (green light indicates enabled tag) and the system will wait for the “Secret PIN-code” entering. Red light of **LED** indicates disabled immobilizer tag.

Disabling radio tag:

LED indicator will light green after entering the programming level. The system will wait for entering the “Secret PIN-code”. Enter the “Secret PIN-code” that is written on the owner’s plastic card. The system will confirm disabling of the radio tag with two sound signals of the siren and a long red **LED** flash. After

that the system will return to the programming menu. If the PIN-code is not entered within 10 seconds or the input is incorrect, a siren will sound one signal, **LED** will produce the series of red and green flashes and the system will return to the programming menu.

Enabling radio tag:

LED indicator will light red after entering the programming level. The system will wait for action. Press **VALET** button once to enable radio tag. The system will confirm enabling with one short sound signal of a siren and a green **LED** light. After that the system will return to the programming menu.

Level 16 – Updating built-in Bluetooth modem firmware

Download the firmware from www.pandorainfo.com and install Pandora BT or Pandect BT application on your mobile device (Android version 4.4 or higher with Bluetooth 4.0 Low Energy or higher support).

To update firmware of the built-in Bluetooth modem, enter programming mode and press **VALET** button 16 times. Find your system in the mobile application, go to detected devices and upload the previously downloaded firmware to the system.

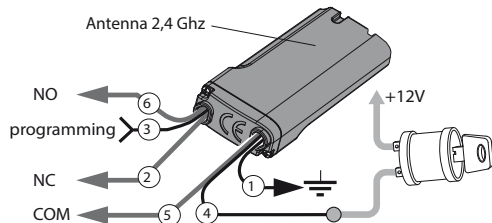

Level 17 – Programming bypass of original immobilizer

Bypass learning procedure is performed on this level. A detailed manual can be found in installation scheme for a car in AlarmStudio.

Enter programming mode and press **VALET** button 17 times. **LED** indicator will be lit green. If system installation was performed correctly on successful engine start using a key, **LED** indicator will flash green. After completing of the procedure, a siren will emit a short sound signal and **LED** indicator will light green. If the learning procedure finishes with an error, **LED** indicator will light red.

Saving changes:

To finish the learning procedure, switch off the ignition and press **VALET** button. The system will return to programming mode.

Level 18 – Registering and unregistering mobile device

The system supports only one mobile device. Registration of a new mobile device (if the system has previously registered device) is not allowed without deleting procedure. When you overwrite the same device in the system memory, you should delete the Bluetooth connection on your mobile device, delete the mobile device from the system memory and then register the mobile device in the system memory.

To register a mobile device, enter the programming mode and press **VALET** button 18 times. **LED** indicator will light green (green light indicates the system is ready to register a mobile device) and the system will enter the mobile device registration mode. Red light of **LED** indicates the system has already had registered mobile device, overwriting of mobile device can be done only after deleting procedure.

Mobile device registration:

LED indicator will light green after entering the level. Open "Pandora Online" mobile application, go to "Bluetooth Control" -> "Not specified" menu and select your device. The application will search for the system via Bluetooth connection. Select the found system, the system and the mobile device will be automatically paired. The system will confirm the pairing with a sound signal of a siren and red light of **LED** indicator.

Deleting mobile device:

LED indicator will light red after entering the level. Press **VALET** button and hold it for more than 4 seconds, release the button. The system will confirm deleting with the series of sound signals of a siren and the system will return to mobile device registration mode (**LED** indicator will light green).

Saving changes:

To finish the registration of a mobile device, **VALET** button should be pressed once, the series of red and green flashes of the status **LED** indicator will confirm the saving, switch on the ignition to automatically save the settings and exit the programming mode.

Levels 19, 20 – Updating radio relays №1, №2 firmware

Download the firmware from www.pandorainfo.com and install Pandora BT or Pandect BT application on your mobile device (Android version 4.4 or higher with Bluetooth 4.0 Low Energy or higher support).

To update firmware of radio relays №1, №2, enter the programming mode and press **VALET** button 19 times for radio relay №1 and 20 times for radio relay №2. Find your system in the mobile application, go to detected devices and upload the previously downloaded firmware to the system.

Online service and mobile application

Registration

Visit pandora-on.com website and register, following the instructions.

System login

After completing of the registration process, you can login to online service via a computer's web browser or via special mobile apps for the Android (Pandora Online) and iOS (Pandora Pro). Only the main functions are available in these apps with DXL 1920/1930L.

Use your previously created login/password to enter the web-site or mobile app.

Adding a car to the online service

Internet service **pandora-on.com** can support simultaneously several telemetry systems, installed on various cars (private car park).

To add a telemetry system (car) to the service, press "Add car" button and go through the process of adding, following the instructions.

To add a car, individual owner's card with registration information is needed (shipped with the system).

Event history

Event history holds more than 100 different types of events that can happen to the system. Every event is saved with date, time, coordinates and status of all control zones at the moment the event has occurred. The number of events in the history is limited. Storage of event history life is no less than 1 month.

Mobile apps for Android and iOS

You can download mobile apps from your device's app store (Google Play, App Store). To access the app, use the login data received from the service at the registration stage.

Pandora Online (Android) and control via Bluetooth

Being in the coverage zone of the Bluetooth connection, Pandora Online can control the system and receive the system status without Internet connections. To do this, perform the mobile device recording procedure after installing the application (see "Recording and deleting a mobile device" section).



WARNING!
CONTROL VIA BLUETOOTH CHANNEL IS AVAILABLE ONLY ON THE DEVICES WITH ANDROID 4.4 AND HIGHER THAT SUPPORTS BLUETOOTH 4.0 LOW ENERGY AND HIGHER. ENABLE BLUETOOTH ON YOUR MOBILE DEVICE TO WORK WITH PANDORA ONLINE APP.

Event history	
18 of January	
	09:00 Arming 165 Fleet St, London EC4A 2DY, UK 09:00
	08:35 Disarming 218 st Johns street, London EC1V 4AT, UK 08:35
	08:24 Engine start 218 st Johns street, London EC1V 4AT, UK 08:24
17 of January	
	18:34 Arming 218 st Johns street, London EC1V 4AT, UK 18:34 <small>pandora-on</small>
	18:00 Disarming 165 Fleet St, London EC4A 2DY, UK 18:00 <small>auto</small>
	17:50 Engine start 165 Fleet St, London EC4A 2DY, UK 17:50 <small>time</small>
	09:00 Arming 165 Fleet St, London EC4A 2DY, UK 09:00

08:24 Engine start
18 of January by command via online service

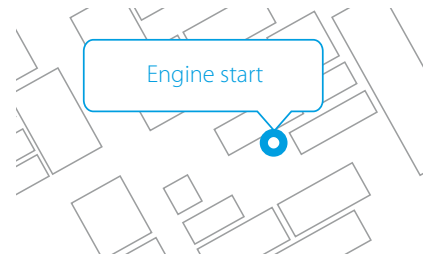
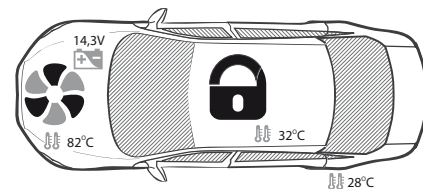

System status information

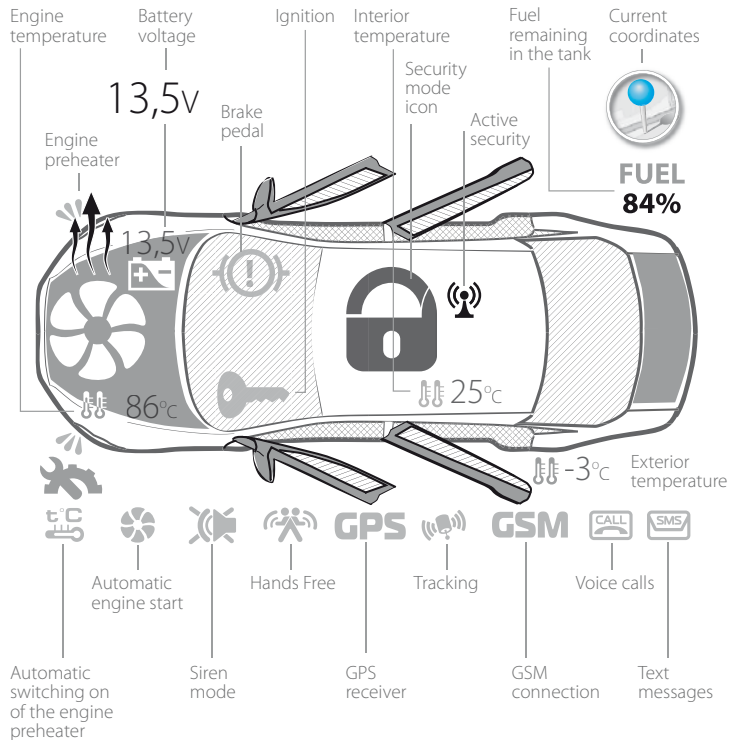

Security and warning zones

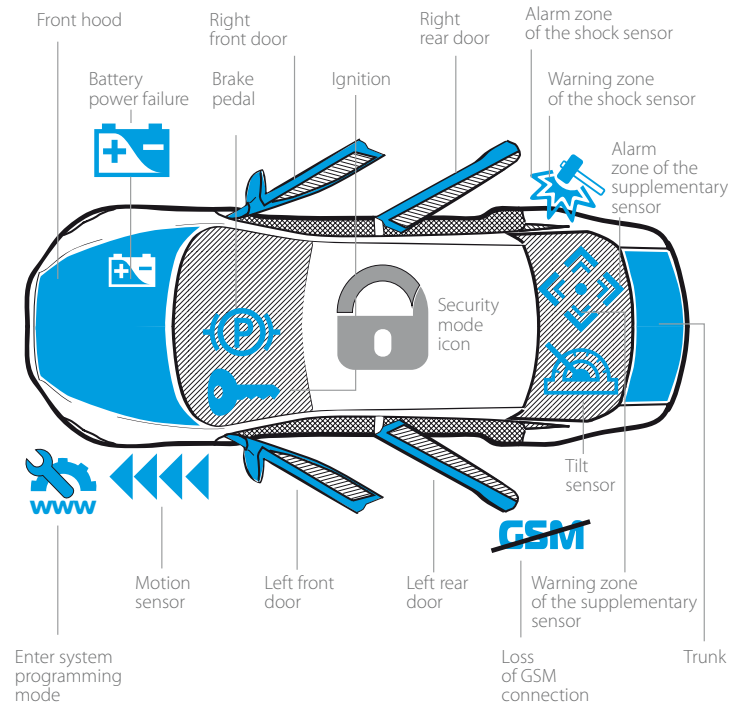

ADDITIONAL DEVICES

Blocking radio relay

Blocking BTR-101 radio relay is optionally available for Pandora DXL 1920L/1930L. Blocking radio relay with built-in accelerometer should be placed in the engine compartment. Herewith zone of built-in aerial 2,4 GHz should not be shielded. Provide a rigid fastening to the car body or to the fixed wirings. It is forbidden to hide the module in wiring. To save energy, radio relay power is connected to the ignition. Radio relay is normally closed and has a full set of contacts. Blocking is carried out on unauthorized movement.

Programming of radio relay is performed on level 6 or 7.

- Select desired level of the programming menu 6, 7 to program radio relay №1, №2 respectively.
- Connect wire 1 of radio relay to the grounding spot.

Apply power (12V) to the contacts 3 and 4 of radio relay. The siren/Beeper will confirm recording of radio relay to the system's memory with 1 beep. Shortly press **VALET** button to save settings.

After successful recording of radio relay switch off and insulate contact 3, connect contact 4 to the constant power 12V or to any wire, which has constant voltage of 12V when ignition is switched on.



Bluetooth tag BT-760



Engine compartment module RHM-03BT



WARNING!
DO NOT PLACE RADIO RELAYS DIRECTLY ON ENGINE!

Useful online resources

www.pandorainfo.com

Official web-site of Pandora.

www.pandorainfo.com/support/alarmstudio-firmware/

User manuals for Pandora systems.

support@pandorainfo.com

Customer support e-mail.

System modules layout

Ask the installer to mark system's modules on the picture provided. This information can be important for diagnostics in case system malfunctions

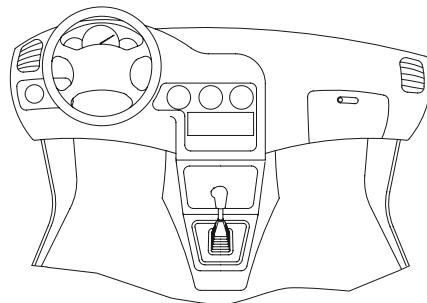

- 1 Base unit
- 2 VALET
- 3 Blocking radio relay
- 4 LED indicator
- 5 Automatic start mo
- 6 GPS receiver

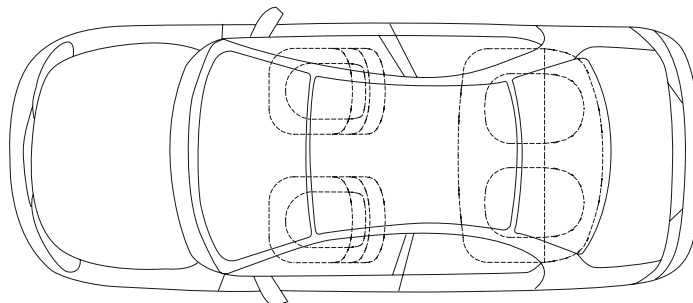

Warranty obligations

Manufacturer guarantees correct operation of the service-security system if exploitation, installation, storage and transportation conditions described in this manual were met.

The system should only be used according to installation scheme and user manuals. The system is meant to be installed by the professional car electronics installers. We recognize that outside Russia the system can be installed by amateurs – those installations are still a subject of limited warranty. The installer should fill in installation certificate that is included in this manual.

Parts malfunctioning during warranty period on the fault of the manufacturer should be repaired or replaced by the installation center of the manufacturer or by certified service center. List of certified service centers outside Russia can be found on pandorainfo.com

The user loses the right for warranty services in the following cases:

- when warranty period expires;
- if exploitation, installation, storage or transportation conditions were not met;
- if there is mechanical damage of the external parts of the system after it is sold. This includes: fire damage, consequential damage in case of car accident, aggressive liquids and water seeping damage, damage caused by improper use;
- if the damage was caused with incorrect settings and parameter adjustment;
- if system devices are replaced with any devices that are not recommended by the manufacturer;
- if manufacturer sealing is broken;
- if there is no properly filled warranty card and installation certificate.

Warranty period is 3 years since the moment of purchase, but no more than 3,5 (three and a half) years since the moment of production.

This warranty does not include batteries of the remotes, as they have their own service life time. Maintenances and repairs of the system with expired warranty period are carried out at the expense of the user on separate contracts between the user and the installer/service center.

Transportation rules

Products should be transported in the original packaging by any means of transport as long as they are protected from mechanical damage and precipitation. Packaged products should be stored on racks in piles of 6 or less boxes, in enclosed, dry, heated rooms (no less than 1m from heating) which exclude possible interaction with moisture, oil products and damaging environmental factors.



WARNING!
WE RECOMMEND YOU TO FILLING OUT INSTALLATION CERTIFICATE AND WARRANTY CARD BY INSTALLER. THESE DOCUMENTS MAY BE REQUIRED FOR CONTACTING CUSTOMER SUPPORT

INSTALLATION CERTIFICATE

I, the undersigned _____
Position, name.

professional installer, certify that installation of the service-security system, specified below, was carried out by me in accordance with manuals and schemes provided by the manufacturer.

Car specifications:

Car model _____ Type _____

Id number (VIN) _____

Registration number _____

Security system specification: _____

Model Pandora DXL 1920L/1930L

Serial number _____

Service center name, full address and installer's stamp

Signature _____ / _____ /

Signator

Work accepted _____ / _____ /

Signator

Date « ____ » _____ 20 ____ year.

ACCEPTANCE CERTIFICATE

Model Pandora DXL 1920L/1930L is in conformity with Electromagnetic Compatibility Directive EMC 2004/108/EC and R&TTE Directive 1999/5/EC.

Serial number _____ Date of production _____

Responsible person's signature (stamp)

Packager _____

Signature (personal stamp)

WARRANTY CARD

Model Pandora DXL 1920L /1930L

Serial number _____

Date of purchase « ____ » _____ 20__ year

Seller's (installer's) stamp

Seller's signature