

Pandora would like to thank you for choosing our DXL 0110L service and security system

Pandora is a brand of Russian Experimental Engineering Factory, a full production cycle electronics R&D facility. We design and produce car service-security systems for more than 10 years and have reached a considerable success on Russian and CIS markets – biggest security system markets in the world. Our systems are made to withstand severe weather conditions and criminal situation of northern Eurasia.

Pandora DXL 0110L is a car service-security system, built for cars with on-board voltage of 12V. It is a complex engineering solution which includes car security system, algorithmic security that detects various events and immobilizer with possible RF tags, all controlled from your OEM key remote. This system is designed to be all-in-one car security solution and requires no additional modules.



WARNING! IT IS STRONGLY ADVISED TO HAVE PROFESSIONAL CAR MECHANIC INSTALLING THE SYSTEM. CERTIFIED INSTALLERS ARE RARE OUTSIDE RUSSIA, BUT ANY CAR ELECTRONICS INSTALLER SHOULD BE ABLE TO INSTALL PANDORA DXL 0110L USING INSTALLATION SCHEME IN THIS MANUAL AND ALARMSTUDIO SOFTWARE. MOST FEATURES ARE HIGHLY DEPENDENT ON COMPETENT INSTALLATION. OUR SYSTEMS ARE THOROUGHLY TESTED FOR QUALITY, SO IF A FEATURE FAILS TO PRODUCE EXPECTED RESULTS, MOST LIKELY THE PROBLEM IS IN IMPROPER INSTALLATION.

It is essential for systems functioning that you read and understand instructions in this manual. Note that all radio devices are subject to interference, which could affect proper performance.

This device has limited external factors resistance. It should not be subjected to water beyond occasional splatter, or operated in temperatures outside -40 to +80° C range

IMPORTANT! Note that this manual describes remote and manual functions for the most part. Functionality of the system is vast and would require a book-sized manual to fully describe. Instead we use a handy software named AlarmStudio that functions as both programming tool and an extended installation & functionality manual. It requires Window sand can be downloaded at pandorainfo.com

Product is in conformity with Electromagnetic Compatibility
Directive EMC 2004/108/EC and R&TTE Directive 1999/5/EC



Table of contents

System features	4
Car security zones	5
System set	5
Siren sounds and light signals	6
Checking the number of registered radio tags/mobile devices	6
Control over system	7
Arming/disarming using radio tag button	7
Arming/disarming in Hands Free mode	7
Arming/disarming in «Slave» mode	7
Mobile application PANDORA BT(Android)	8
Immobilizer mode	9
Antihijack mode	10
Code immobilizer using original car controls	10
Replacing immobilizer tag battery	10
Control over system in case of emergency	10
System installation	13
General installation requirements	13
Wiring diagram	16

System configuration and programming 18

Entering the programming menu, entering PIN-code	18
Preparing to program the system using a computer	19
Updating firmware	19
Programming using VALET button	20

Additional devices 28

Information 29

Useful online resources	29
Warranty obligations	29
Installation certificate	31
Acceptance certificate	32
Warranty card	32

System features

Base unit

- Mobile application for Android.
- «Secret PIN-code» for disarming and disabling immobilizer.
- Hands Free mode for arming/disarming.
- Two «Anti-Hi-Jack» algorithms.
- «Automating arming» mode.
- «Code Immobilizer» mode.
- Built-in 2.4 GHz module supports Bluetooth 4.2 LowEnergy.
- Dialog coding of control commands.
- Individual 128-bit encryption key. User can change the key during tag re-learning procedure.
- Built-in accelerometer
- Built-in integral accelerometer for determining motion and shocks with adaptive processing algorithm and sensitivity controls.
- Advanced processing of sensor data, eliminating false alarm possibilities.
- Firmware updates via built-in micro-USB socket.

Immobilizer tags

- Dialog coding of control commands.
- Individual 128-bit encryption key.
- Built-in LED indicator.
- Built-in button to control over security modes.
- Built-in accelerometer.

Car security zones

Pandora DXL 0110L service-security system guards following independent zones:

- car doors perimeter
- front hood triggers
- trunk triggers
- ignition trigger
- brake pedal button pressing
- triggering of the shock sensor (warning level)
- triggering of the shock sensor (alarm level) triggering of the motion sensor
- triggering of the tilt sensor
- marker lights left on notification when arming*.

System set

Base unit	1.
Immobilizer tag	1.
Cable with VALET button	1.
User installation manual	1.
Personal owner's card	1.
Beeper (compact sound emitter)	1.
Main cable	1.
Fastening kit	1.
Packaging	1.

Manufacturer reserves the right to change set and construction of the product to improve its technological and operational parameters without notification.

* - Availability of this function depends on car make and model

Siren sounds and light signals

Signal	Description
Alarm mode, PANIC mode	Incessant sound and light signals for 30 seconds
Arming	1 sound and 1 light signals
Disarming	2 sound and 2 light signals
«Sensors triggered» signal when disarming	4 sound and 4 light signals
«Sensor malfunction» signal when arming	4 sound and 4 light signals
Sensor warning level triggered	1 sound and 1 light signals
«Search car»	1 sound and 1 light signals

Checking the number of registered radio tags/mobile devices

Number of registered tags and mobile device can be checked by taking off and putting back on battery terminal. The system will emit short sound signals from the siren and Beeper with less than 1 sec. interval. The number of the signals equals to the number of recorded tags. After a pause of 2 seconds the system signal will indicate registered mobile device.

You can also check the number of registered tags and mobile device by the number of green and red flashes of **LED** indicator. Number of registered tags can be checked every time the ignition is switched on when the system is disarmed. Number of green **LED** flashes will indicate the number of recorded tags, following red flash will indicate registered mobile device.

CONTROL OVER SYSTEM

Arming/disarming using radio tag button

To arm/disarm the system, RF tag should be in radio coverage area (within a radius of 5 meters from the car). The system produces a protected (AES-128 encryption) interactive high-speed exchange of authorization codes in the frequency range 2,4 GHz on one of 125 channels. To arm the system when the ignition is switched off, shortly press the tag button. The system will confirm the command receiving with 1 short sound signal and 1 flash of turn indicators. To disarm the system, shortly press the tag button. The system will confirm the command receiving with 2 short sound signals and 2 flashes of turn indicators. Each button press will be confirmed with **LED** indicator flash of the tag that indicates the battery is functioning correctly. If **LED** indicator does not flash or light, the tag battery should be replaced (see «Replacing immobilizer tag battery» section).



Arming/disarming in Hands Free mode

The system allows for programmable automatic arming and disarming algorithm (Hands Free mode). To arm the system when the ignition is switched off, move with the remote tag away from the car at a distance greater than the regular radio coverage (10 meters for 2,4 GHz) – the system will be armed automatically. To disarm the system, move toward the car with remote tag.

You can enable and disable this function using Pandora AlarmStudio application.

Arming/disarming in slave mode

In this mode it is possible to monitor the status of original security system of the car via CAN-bus or by analog inputs. When arming and disarming original security system, Pandora will be armed and disarmed respectively.

There is an option in the system settings named «Disable disarming when the tag is not present». When this option is enabled, disarming procedure will be performed only if there is a tag in the radio zone.

You can enable and disable this function using Pandora AlarmStudio application.

PANDORA BT (ANDROID) application

Pandora BT application is an additional tool for controlling and managing the system state. The system can connect only to the mobile device that was previously registered in the system memory. Registration is performed via encrypted 2.4 GHz channel with the Bluetooth Low Energy protocol support. Pandora BT is available on Google Play for devices with Android 4.4 or higher and with Bluetooth 4.0 Low Energy or higher module.

Installing the application

You can download free Pandora BT application from application store (Google Play). After installing the application, perform the mobile device registration procedure (see p. 26 «Registration and deleting a mobile device»).

The application usage

The system should be in the Bluetooth radio coverage zone. Start Pandora BT, the application will automatically find the system and make a connection; after that the main menu of the application will open.

The main menu «Control» displays the current status of the system and allows you to control the system using multifunction buttons. Control buttons is used for controlling the car and quick access to the system functions. The functions can be switched on or off or the car can be remotely controlled by pressing and holding until the progress bar will fully loaded (3 seconds), this is done to protect against accidental button press. You can change button location and select the desired functional in the «Control buttons» settings.



WARNING!
ENABLE BLUETOOTH FUNCTION ON YOUR MOBILE DEVICE
TO USE PANDORA BT APPLICATION

Immobilizer mode

This mode is enabled by default. Use Pandora AlarmStudio application to disable this mode. When switching on the ignition, base unit of Pandora security system performs a search for immobilizer tags in radio zone. If no radio tags were detected when the ignition is switched on, the system will block the engine. Engine blocking will occur immediately or when the car starts moving, it depends on block implementation and system settings.

Anti-Hi-Jack-1 mode

This mode is disabled by default. Use Pandora AlarmStudio application to enable this mode. Anti-Hi-Jack-1 mode helps to prevent aggressive seizure of the car using delayed engine blocking on any door opening/closing. Every time on opening/closing a door (when the ignition is switched on), immobilizer requests response from a tag using unique algorithm. After a door was opened or closed while the engine is running, if the system cannot detect a radio tag, the engine will be stopped after 1 minute (general safety requirement for car movement). «Engine blocking warning» ringtone will play from siren and beeper before blocking. When warning signals end, the system will block the engine. Engine blocking will occur immediately or when the car starts moving, it depends on block implementation and system settings.

Anti-Hi-Jack-2 mode

This mode is disabled by default. Use Pandora AlarmStudio application to enable this mode. Anti-Hi-Jack-2mode helps to prevent aggressive seizure of the car using delayed engine blocking on radio tag disappearance. Every time when switching on the ignition, immobilizer requests response from a tag using unique algorithm. When the engine is running, if the system cannot detect a radio tag, the engine will be stopped after 1 minute (general safety requirement for car movement). «Engine blocking warning» ringtone will play from siren and beeper before blocking. When warning signals end, the system will block the engine. Engine blocking will occur immediately or when the car starts moving, it depends on block implementation and system settings.

Code immobilizer using original car controls

Code immobilizer is a function that allows disarming, disabling engine blocking and controlling timer channels using original car controls (button, lever or pedal). To enter immobilizer code, programmed button (lever, pedal) should be pressed a number of times equal the first digit of the code. Pauses between presses should not exceed 1 second. Pauses more than 1 second will be interpreted as the start of next digit input. Immobilizer code can consist max of 4 digits from 1 to 9.

After entering a correct immobilizer code, depending on the settings, either the engine blocking will be lifted or a programmed timer channel will be activated or the system will be disarmed.

Replacing immobilizer tag battery

Carefully open the cover of the tag's battery compartment. Extract discharged battery and insert a new one keeping in mind the correct polarity. Replacing a battery will not cause a loss of tag code information, as authorization data is stored in the non-volatile memory of the MCU. Carefully close the cover of the tag's battery compartment. All elements of construction should be rigidly locked in places. If it is so, the tag can be operated as usually.



Control over system in case of emergency



WARNING!
CAREFULLY REMOVE THE PROTECTIVE LAYER, DO NOT USE SHARP OBJECTS TO AVOID DAMAGING OF HIDDEN INFORMATION UNDER A PROTECTIVE LAYER.

In case you cannot disarm the system using a tag, owner's individual PIN-code can be used. Individual PIN-code is written on the owner's plastic card under protective layer. The code must be entered only when the base unit is powered and the ignition is switched off. PIN-code should be entered using external or located on the base unit VALET button. The digits input and correct input is indicated by the beeper sounds.

Entering the PIN-code.

- Enter the first digit of the code using **VALET** button. Press the button a number of times, equal to the first digit. Pauses between presses should not exceed 1 second. Pause for more than 1 second and a short sound of the Beeper confirm the input of the first digit. Then you can enter the next digit.
- Enter the second digit of the code using **VALET** button. Press the button a number of times, equal to the second digit. Pauses between presses should not exceed 1 second. Pause for more than 1 second and a short sound of the Beeper confirm the input of the second digit. Then you can enter the next digit.

- Enter the third digit of the code using **VALET** button. Press the button a number of times, equal to the third digit. Pauses between presses should not exceed 1 second. Pause for more than 1 second and a short sound of the Beeper confirm the input of the third digit. Then you can enter the next digit.

- Enter the fourth digit of the code using **VALET** button. Press the button a number of times, equal to the fourth digit. Pauses between presses should not exceed 1 second. The system will confirm correct PIN-code with the series of sound signals of the Beeper and the system will be disarmed. If the input was incorrect, it will be indicated with a short sound signal of Beeper and the system will stay in previous state. New input can be attempted after 5 seconds.

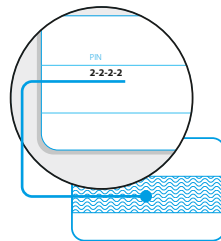

After correct input of PIN-code the system will enter programming mode, if it was disarmed and the ignition was switched off.

For emergency arming when the engine is stopped, press and hold **VALET** button for 3 seconds. The system will be armed in 30 seconds.

Enabling/Disabling immobilizer radio tag

Write down or remember the «Service PIN-code»



WARNING!
IT IS HIGHLY RECOMMENDED TO CHANGE FACTORY
PRESET OF THE «SERVICE PIN-CODE» FOR IMPROVING
SECURITY OF THE SYSTEM

To disable immobilizer radio tag, enter level 15 (the system should be in programming mode). Enter the «Secret PIN-code» to disable radio tag or press **VALET** button once to enable radio tag.

Enter the «Service PIN-code» to enter programming mode (factory preset of the service PIN-code is «1-1-1»). You can enter the code only if the base unit is powered, the ignition is switched off, and the system is disarmed. If there is no «Service PIN-code», you can enter programming mode using the «Secret PIN-code» written on the owner's card. After entering the programming mode, press **VALET** button 15 times (pauses between presses should not exceed 1 second). The system will confirm entering the level with 15 sound signals of the Beeper.

Disabling radio tag:

The system will wait 10 seconds for entering the «Secret PIN-code». If the PIN-code is not entered within 10 seconds, the system will return to the programming menu. Enter the «Secret PIN-code» that is written on the owner's plastic card. The system will confirm disabling of the radio tag with two sound signals of the siren and the series of the sound signals of the Beeper. After that the system will return to the programming menu. Switch on the ignition to exit programming mode.

Enabling radio tag:

The Beeper will emit a long sound signal after entering the level. The system will wait for action. Press **VALET** button once to enable radio tag. The system will confirm enabling with one short sound signal of the siren/Beeper. After that the system will return to the programming menu. Switch on the ignition to exit programming mode.

SYSTEM INSTALLATION

General installation requirements

- Install base unit only inside car interior.
- Install securely each system's component, as conditions of the car standard operation can harm functionality of the alarm system and cause damage to the car original systems, including the elements of safety in motion.
 - The system installation should be performed when the system sockets and the negative battery terminal are disconnected.
 - The base unit power supply should be switched off when connecting to CAN-bus.
 - The system installation can be performed via twisting together or via lead-tin soldering followed by isolation of a switching place.
 - When wiring, pay attention to sections and materials of switched conductors, if they are different, bring electrochemical potentials to the minimal difference. The isolation should not allow for moisture to reach wiring, as the presence of moisture will increase electrochemical destruction of wires (this is especially important for the large current circuits).
 - Switched connections should be placed as high as it is possible in the cavities so water condensate will not form drops on the switching location.
 - To avoid the destruction of compounds by car vibration, ensure that there is a bit of free length to the wiring, providing enough sagging.
 - Do not allow wiring in places where the wires isolation can be destroyed by abrasion.
 - Electronic system units should be placed sockets down and as high as possible to avoid condensate reaching electronic components through the socket.
 - When installing base unit, secure it to the car body for correct operation of in-built shock sensor.
 - All unused system wires during the installation must be insulated and secured to prevent accidental touching of a car body or other wires.

WIRING DESCRIPTION

- **Wire «1» (White) (DATA TX)** — It connects to appropriate additional devices wires (optional).

- **Wire «2» (Red-black) (LED/VALET)** — It should be connected to the red wire of VALET button. Black wire of VALET button connects to the grounding spot.

- **Wire «3» (Orange-white) («CAN1-High»)** — It connects to appropriate CAN-High wire of the car.

- **Wire «4» (Yellow-white) («CAN2-High»/CH2)** — Factory setting is «Open central lock». A negative impulse of 0,8 seconds is formed on the wire to open central lock. Logic of the channel's operation can be set in the table of system outputs. When the car model code with support for CAN2-bus is selected, channel CH2 stops to operate as an output.

- **Wire «5» (Gray) (CH1/INP1)** — Factory setting is «Beeper OUT». The wire connects to the corresponding «-» wire of the Beeper sound emitter. Sound signals from the Beeper location should be heard from the driver's seat. «+» out should be connected to reliable conductor with constant voltage of 12V. LED indicator can be connected in parallel to Beeper through a 1000...1500 Ohm resistor. Negative output of additional channel, maximum load current is 200 mA. This output is multipurpose, it can operate as an input or output in accordance with selected logic.

- **Wire «6» (Green) (CH4/INP4)** — Factory setting is «Control turn indicators». This wire connects to the hazard flashers button. Negative output of additional channel, maximum load current is 200 mA. This output is multipurpose, it can operate as an input or output in accordance with selected logic.

- **Wire «7» (White-blue) (INP5)** — Factory setting is «Brake pedal limit switch». This wire connects to the brake pedal button where 12V voltage appears when the pedal is pressed (stop lights wire). Brake pedal signal is one of the system's security zones. This input is multipurpose, it can operate in accordance with selected logic.

- **Wire «8» (Black) («Ground»)** — It should be connected to the car body in a grounding spot. This wire should be connected first during installation.

- **Wire «9» (Blue) (DATA RX)** — It connects to appropriate additional devices wires (optional).

- **Wire «10» (Brown-white) (INP3)** — Factory setting is «Front hood limit switch». This wire connects to appropriate wire that becomes grounded when the front hood opens. This input is multipurpose, it can operate in accordance with selected logic.

- **Wire «11» (Orange-black) («CAN1-Low»)** — It connects to appropriate CAN-Low wire of the car.

- **Wire «12» (Yellow-black) («CAN2-Low»/CH5)** — Factory setting is «Close central lock». A negative impulse of 0,8 seconds is formed on the wire to close central lock. Logic of the channel's operation can be set in the table of system outputs. When the car model code with support for CAN2-bus is selected, channel CH5 stops to operate as an output.

- **Wire «13» (Blue-black) (CH3)** — Factory setting is «N.O. Blockage». This wire is used to control blocking relay with a normally open logic (it becomes grounded when switching on the ignition and security system is armed). Negative output of additional channel, maximum load current is 200 mA. This output is multipurpose, it can operate in accordance with selected logic.

- **Wire «14» (Yellow) (INP2)** — Factory setting is «Ignition». This wire connects to ignition switch or to appropriate wire where 12V voltage appears when ignition is switched on. This input is multipurpose, it can operate in accordance with selected logic

- **Wire «15» (Purple) (CH6)** — Factory setting is «Siren». It connects to siren control wire (+). This output is multipurpose, it can operate in accordance with selected logic (maximum load current is 2A).

- **Wire «16» (Red) («Power supply» +12V)** — It should be connected to reliable conductor with constant voltage of 12V.

Pandora DXL 0110L

WIRING DIAGRAM

ATTENTION!

Before starting the installation of the system, choose the car model in Alarm studio (CAN bus protocols).

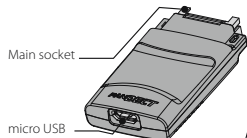

DO NOT SHIELD!
BUILT-IN ANTENNA!

Base unit (view from the bottom side)

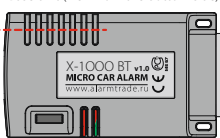

MAIN SOCKET

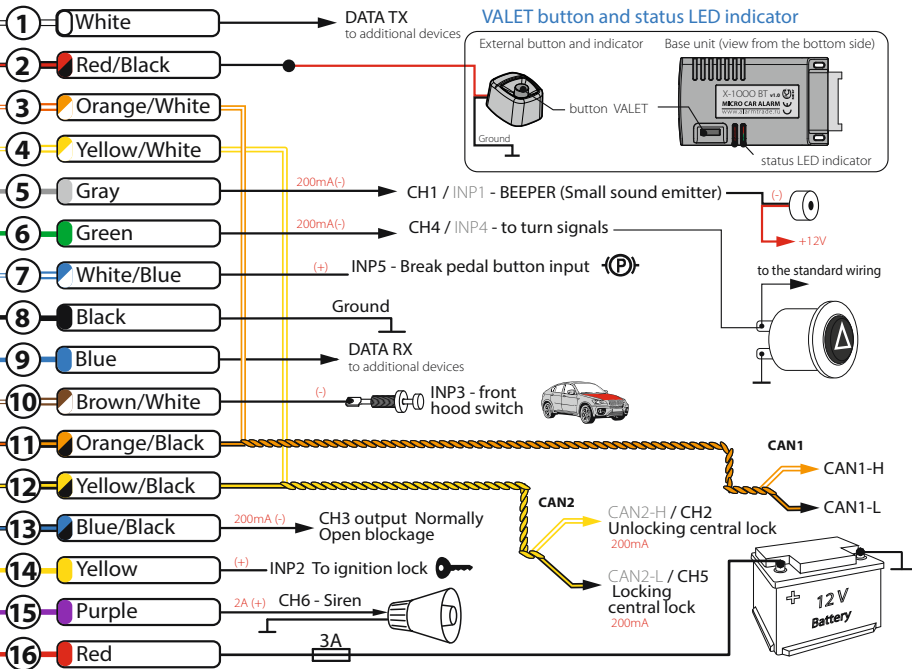
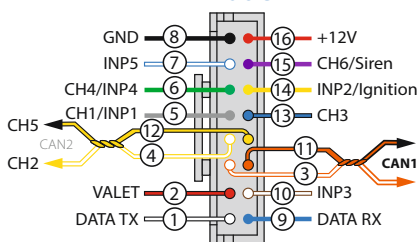

INSTALLATION AND CONFIGURATION OF THE SYSTEM

Entering the programming menu, entering PIN-code

To change the system settings or program the system using a computer or **VALET** button, the system should be in programming mode. Enter programming mode by entering «Service PIN-code» (factory preset is 1-1-1-1). PIN-code should be entered using external or located on the base unit **VALET** button. The input is indicated by the sounds of the Beeper or by flashes of the **LED** indicator located on the base unit. You can enter the code only if the base unit is powered from USB socket or from external power supply, the ignition is switched off and the system is disarmed.

Entering PIN-code:

- Enter the first digit of the code using **VALET** button. Press the button a number of times, equal to the first digit. Pauses between presses should not exceed 1 second, each pressing will confirm with orange **LED** indicator flash. Pause for more than 1 second and red **LED** indicator with a short sound signal of the Beeper confirm the input of the first digit. Then you can enter the next digit.
 - Enter the second and third digit of the code using **VALET** button in the same way.
 - Enter the fourth digit of the code using **VALET** button. The system will confirm correct PIN-code with red and green flashes of **LED** indicator with multiple sound signals of the Beeper and the system will enter programming mode. If the input was incorrect, it will be indicated with long red flash and a short sound signal of the Beeper. New input can be attempted after 5 seconds.

Exit programming mode:

To exit programming mode turn on the ignition or turn off power of the base unit. The system will reboot programmatically (all changes will be saved) after exiting programming mode using ignition. All ways to exit the programming menu are accompanied by sound signals of the siren/Beeper and light signals of the LED indicator. Light signals indicate the number of registered devices: first green flashes indicate the number of registered radio tags, red flash indicates registered mobile device.

Status indicator lights during PIN-code entering:

Short orange flash	Confirmation of VALET button pressing
Short red flash	Confirmation of entering a PIN-code digit
Red and green flashes	Entered PIN-code is correct
Long red flash	Entered PIN-code is incorrect

Preparing to program the system using a computer

The system allows programming all settings and updating software of the base unit via micro-USB cable. If base unit has not yet been installed in the vehicle, it will be powered via micro-USB cable while programming. To program using a computer, you need a standard USB cable, a computer with Windows XP/Vista/7/8/10 and Pandora AlarmStudio application (you can download it from pandorainfo.com).

In preparation to the programming these stages should be followed:

- connect the system and PC via USB cable;
- start Pandora AlarmStudio;
- enter the programming settings mode by entering the service PIN-code.

Updating firmware

It is recommended to update firmware of the base unit before installing and programming the system (actual version of the firmware you can download from pandorainfo.com). You can update firmware using AlarmStudio application after entering programming mode or using quick boot algorithm (PIN-code is not required).

Quick boot mode: open AlarmStudio; de-energize and disconnect the system; press and hold **VALET** button located on the base unit; release the button immediately after connecting the system and a computer via USB cable; the system will enter boot mode.

If the boot mode has been interrupted for some reason and the status indicator lights red, you need to load firmware using quick boot mode (without entering PIN-code).

Programming using VALET button

The system allows programming some settings using **VALET** button. To configure all settings use a computer to program the system.

Enter programming mode by entering «Service PIN-code». Use **VALET** button to enter the desired level number (press the button a number of times, equal to level number; pauses between presses should not exceed 1 second). The system will confirm correct input with red **LED** flashes and short sound signals of the siren/Beeper and proceed to the desired level. If the input was incorrect, the system will not confirm input and will await a new level input after a series of green and red flashes

Level 1	Registration of radio tags (BT760)
Level 2	Changing the factory preset service PIN-code
Level 3	Recording idle speed
Level 4	Resetting to factory settings
Level 5	Registration of Bluetooth engine compartment module (RHM-03 BT)
Level 6, 7	Registration of Bluetooth radio relays №1, №2 (BTR-101)
Level 8	Reserved
Level 9	Reserved
Level 10	Configuring system settings via the wireless interface
Level 11	Programming and configuring «immobilizer PIN-code»
Level 12	Reserved
Level 13, 14	Reserved

Level 15	Emergency disabling of immobilizer radio tag
Level 16	Update Bluetooth modem firmware
Level 17	Reserved
Level 18	Register and unregister mobile device
Level 19, 20	Update radio relays №1, №2 firmware
Level 21	Update Bluetooth engine compartment module firmware (RHM-03 BT)

Level 1 – Registration of radio tags into the system's memory

Prepare to register all radio tags (you can register up to 3 tags), install batteries in the radio tags.

Enter programming menu and then press **VALET** button once. **LED** indicator will light green and the system will enter the tag registration mode. Tags are registered (paired) one by one, in any order and without time limit. All previously registered radio tags will be removed when you overwrite new tags or overwrite old tags.

Registration of radio tags:

Press control button on the tag and hold it for 6 seconds (6 flashes of tag status indicator), release the button after the sixth flash. If the recording was successful, the siren/Beeper will emit 1 beep, after that you can move to recording the next tag.

Saving changes:

To finish the registration of the radio tags into the system, **VALET** button should be pressed once again, the series of red and green flashes of status **LED** indicator with the series of sound signals of the Beeper will confirm the saving.

Level 2 – Changing the factory preset service PIN-code

Prepare new value of the «Service PIN-code», it should consist of 4 digits (from 1 to 9). Write down or remember the new PIN-code.

Enter programming menu and then press **VALET** button twice. The system will enter «Changing Service PIN-code» mode and the status **LED** indicator will turn off.

Changing «Service PIN-code»:

- Enter the first digit of the code using **VALET** button. Press the button a number of times, equal to the first digit. Pauses between presses should not exceed 1 second, every pressing will confirm with orange **LED** indicator flash. Pause for more than 1 second and red **LED** indicator with a short sound signal of the Beeper confirm the input of the first digit. Then you can enter the next digit.
- Enter the other numbers in the same manner. The input of the fourth number will be confirmed by series of red and green **LED** indicator flashes with multiple sound signals of the Beeper. The system will wait for PIN-code re-entering.
- Enter all four digits again;
- If you were able to correctly enter code twice, the indicator will produce series of red and green flashes and the Beeper will emit the series of sound signals, new PIN-code will be recorded, the system will return to the programming mode. In case of the incorrect code input the indicator will be lit red and the Beeper will emit a long sound signal, the system will return to a programming mode.

Level 3 – Recording idle speed

To timely turn off the starter during automatic or remote engine start via digital or analog tachometer output and the correct operation of the «Smart Turbo Timer», it is necessary to record the engine's idle speed.

To record idle speed to the non-volatile system's memory, enter the programming menu. Press **VALET** button three times. Switch on the ignition and start the engine after entering this level of programming (the engine should be warmed-up, idle speed should match the stable idle speed of the warmed-up engine). The system will confirm the presence of the idle speed status with green flashes of the **LED** status indicator. Wait until the stable idle speed will be reached and save the changes.

Saving changes:

Press **VALET** button once to save idle speed. Successful recording of the idle speed will be confirmed with the series of red and green flashes of the **LED** status indicator and the series of sound signals of the Beeper. The system will exit programming menu and reboot after saving idle speed.

Level 4 – Resetting to factory settings.

The procedure recovers the system's factory settings without deleting previously registered devices (tags, mobile device, relays, etc.), that was previously stored in the non-volatile memory.

To reset the factory settings enter the programming mode and press **VALET** button four times. Press and hold **VALET** button for more than 4 seconds until siren/Beeper sound, then release the button. The system will confirm the resetting to the factory settings with a long red flash of the **LED** indicator with the multiple sound signals of the Beeper. After that the system will return to a programming mode.

Level 5 – Registration of Bluetooth engine compartment module

To register the Bluetooth engine compartment module, enter the programming mode and press **VALET** button 5 times. The **LED** indicator will light green and the system will enter the registration of the engine compartment module mode. Connect the module in accordance with installation manual. The system will confirm the registration with a short sound signal of the Beeper.

Save changes:

To finish the registration of the engine compartment module, **VALET** button should be pressed once again, the series of red and green flashes of the status **LED** indicator with the multiple sound signals of the Beeper will confirm the saving, switch on the ignition to automatically save the settings and exit the programming mode.

Level 6, 7 – Registration of Bluetooth radio relays №1, №2

The registration of radio relays is performed one by one starting from the 6 level: radio relay №1 is registered at the 6 level; radio relay №2 is registered at the 7 level. The radio relay can be overwritten only at the level of its initial registration.

To register of the Bluetooth radio relays №1, №2, enter the programming mode and press **VALET** button 6 times for radio relay №1 or 7 times for radio relay №2. The **LED** indicator will light green and the system will enter the registration of the radio relay mode. Connect the relay in accordance with installation manual. The system will confirm the registration with a short sound signal of the siren/Beeper.

Save changes:

To finish the registration of the Bluetooth radio relay, **VALET** button should

be pressed once again, the series of red and green flashes of the status **LED** indicator with the multiple sound signals of the Beeper will confirm the saving, switch on the ignition to automatically save the settings and exit the programming mode.

Level 10- Configuring system settings via the wireless interface

This function is under construction.

Level 11 – Programming and configuring «immobilizer PIN-code»

To programming «immobilizer PIN-code», enter the programming mode and press **VALET** button 11 times. The level is divided into 3 sublevels (Sublevel 11.1 – Selecting the buttons; sublevel 11.2 entering PIN-code; sublevel 11.3 – confirmation of the PIN-code input).

The system will automatically enter the sublevel 11.1 (selecting the buttons) after entering the level 11. The system can determine the buttons via analog «Code immobilizer» input or via digital protocol of a car. It is necessary to configure the analog input (INP) as «Code immobilizer» in the settings of the base unit inputs when implementing the «Code immobilizer» via analog input. It may be necessary to switch on the ignition after entering the level 11 of programming (if the car bus is active only when the ignition is switched on) when implementing the «Code immobilizer» via digital car bus protocol.

After selecting active buttons enter the sublevel 11.2 (Entering PIN-code) by pressing **VALET** button once. Program the PIN-code using selected buttons at this sublevel; press **VALET** button once and enter the PIN-code again. To confirm re-entering the PIN-code and save all the settings press **VALET** button once again.

Sublevel 11.1 – Selecting the button:

This sublevel is used to select active buttons via digital protocol of a car or via analog input «Code Immobilizer». To determine the activity of the analog «Code Immobilizer» input, apply potential to the corresponding input (INP) of the base unit, **LED** indicator will be flashing orange. If you determine buttons via digital protocol select one or more buttons (up to four) for entering the secret code of the immobilizer.

To do this press the selected button, **LED** indicator will confirm input with orange flashes. If there are no orange flashes when any button is pressed, then

this button is not recognized by the system, select a different button. Repeat the procedure to select the second, third, fourth button and enter the next sublevel. To enter the next sublevel press **VALET** button once.

Sublevel 11.2 – Entering PIN-code:

Program immobilizer deactivation PIN-code using selected button or buttons. Enter the first digit by pressing the previously selected button (pauses between presses should not exceed 1 second). The base unit will confirm entering with red flash of **LED** indicator. Enter the second (third, fourth) digit by pressing the previously selected button. The base unit will confirm entering of each digit with red flash of **LED** indicator.

Input the required number of digits (up to 4) and then press **VALET** button. The system will confirm receiving of the secret validator code with long red flash of **LED** indicator and will wait for confirmation of PIN-code.

Sublevel 11.3 - Confirmation of the PIN-code input:

Enter PIN-code again similarly to the procedure (level 11.2 – Entering PIN-code) and press **VALET** button. The system will confirm correct PIN-code with red and green flashes of **LED** indicator and will memorize PIN-code, then will proceed to the programming mode awaiting level input. Incorrect confirmation is indicated with long red flash of **LED** indicator, after that the system will return to a programming mode

Level 15 – Disabling/enabling of immobilizer tag

To disabling/enabling of immobilizer tag enter the programming menu and press **VALET** button 15 times. The **LED** indicator will light green (green light indicates enabled tag) and the system will wait for the «Secret code» entering. Red light of **LED** and 5-second sound signal of the Beeper indicates disabled immobilizer tag.

Disabling radio tag:

The system will wait 10 seconds for entering the «Secret PIN-code». If the PIN-code is not entered within 10 seconds, the system will return to the programming menu. Enter the «Secret PIN-code» that is written on the owner's plastic card. The system will confirm disabling of the radio tag with two sound signals of the siren and the series of the sound signals of the Beeper. After that the system will return to the programming menu. Switch on the ignition to exit programming mode

Enabling radio tag:

The Beeper will emit a long sound signal after entering the level. The system will wait for action. Press **VALET** button once to enable radio tag. The system will confirm enabling with one short sound signal of the siren/Beeper. After that the system will return to the programming menu. Switch on the ignition to exit programming mode

Level 16 – Updating built-in Bluetooth modem firmware

Download the firmware from www.pandorainfo.com and install Pandora BT application on your mobile device (Android version 4.4 or higher with Bluetooth 4.0 Low Energy or higher support).

To update firmware of the built-in Bluetooth modem, enter the programming mode and press **VALET** button 16 times. Find your system in the mobile application, go to detected devices and upload the previously downloaded firmware to the system.

Level 18 – Registration and deleting a mobile device

The system supports only one mobile device. Registration of a new mobile device (if the system has previously registered device) is not allowed without deleting procedure.

When you overwrite the same device in the system memory, you should delete the Bluetooth connection on your mobile device, delete the mobile device from the system memory and then register the mobile device in the system memory.

To register a mobile device, enter the programming mode and press **VALET** button 18 times. The **LED** indicator will light green (green light indicates the system is ready to register a mobile device) and the system will enter the mobile device registration mode. Red light of **LED** indicates the system has already had registered mobile device, overwriting of mobile device can be done only after deleting procedure.

• Mobile device registration:

The **LED** indicator will light green after entering the level. Open the mobile application and press «Search device» button. The application will search for the system via Bluetooth connection. Select the found system, the system and the mobile device will be automatically paired. The system will confirm the pairing with a sound signal of the siren/Beeper and red flash of **LED** indicator.

• Deleting mobile device:

The **LED** indicator will light red after entering the level. Press **VALET** button and hold it for more than 4 seconds, release the button. The system will confirm deleting with the series of sound signals of the siren/Beeper and the system will return to mobile device registration mode (**LED** indicator will light green).

• Save changes:

To finish the registration of a mobile device into the system, **VALET** button should be pressed once, the series of red and green flashes of the status **LED** indicator with the series of the sound signals of the Beeper will confirm the saving, switch on the ignition to automatically save the settings and exit the programming mode.

Level 19, 20 – Updating radio relays №1, №2 firmware

Download the firmware from www.pandorainfo.com and install Pandora BT application on your mobile device (Android version 4.4 or higher with Bluetooth 4.0 Low Energy or higher support).

To update firmware of radio relays №1, №2, enter the programming mode and press **VALET** button 19 times for radio relay №1 and 20 times for radio relay №2. Find your system in the mobile application, go to detected devices and upload the previously downloaded firmware to the system.

ADDITIONAL DEVICES

Blocking radio relay

For Pandora DXL 0110L optionally blocking BTR-101 radio relay is available. Blocking radio relay with built-in accelerometer should be placed in the engine compartment. Herewith zone of built-in aerial 2,4 GHz should not be shielded. Provide a rigid fastening to the car body or to the fixed wirings. It is forbidden to hide the module in wiring. To save energy, radio relay power is connected to the ignition. Radio relay is normally closed and has a full set of contacts. Blocking is carried out on unauthorized movement.

Programming of radio relay is performed on level 6 or 7.

- Select desired level of the programming menu 6, 7 to program radio relay №1, №2 respectively.
- Connect wire 1 of radio relay to the grounding spot.
- Apply power (12V) to the contacts 3 and 4 of radio relay. The siren/Beeper will confirm recording of radio relay to the system's memory with 1 beep. Shortly press **VALET** button to save settings.
- After successful recording of radio relay switch off and insulate contact 3, connect contact 4 to the constant power 12V or to any wire, which has constant voltage of 12V when engine is running.

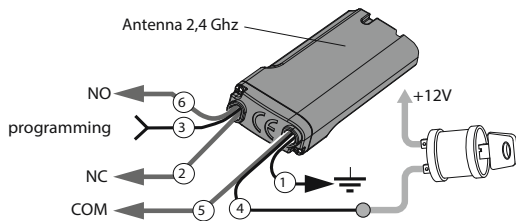

WARNING!
DO NOT PLACE RADIO RELAYS DIRECTLY ON ENGINE!



Radio tag BT-760



Engine compartment module RHM-03BT

Useful online resources

www.pandorainfo.com

Official web-site of Pandora.

support@pandorainfo.com

Customer support email.

Warranty obligations

Manufacturer guarantees correct operation of the service-security system if exploitation, installation, storage and transportation conditions described in this manual were met.

The system should only be used according to installation scheme and user manuals. The system is meant to be installed by the professional car electronics installers. We recognize that outside Russia the system can be installed by amateurs – those installations are still a subject of limited warranty. The installer should fill in installation certificate that is included in this manual.

Parts malfunctioning during warranty period on the fault of the manufacturer should be repaired or replaced by the installation center of the manufacturer or by certified service center. List of certified service centers outside Russia can be found on pandorainfo.com

The user loses the right for warranty services in the following cases:

- when warranty period expires;

- if exploitation, installation, storage or transportation conditions were not met;
- if there is mechanical damage of the external parts of the system after it is sold. This includes: fire damage, consequential damage in case of car accident, aggressive liquids and water seeping damage, damage caused by improper use;
- if the damage was caused with incorrect settings and parameter adjustment;
- if system devices are replaced with any devices that are not recommended by the manufacturer;
- if manufacturer sealing is broken;
- if there is no properly filled warranty card and installation certificate.

Warranty period is 3 years since the moment of purchase, but no more than 3,5 (three and a half) years since the moment of production.

This warranty does not include batteries of the remotes, as they have their own service life time. Maintenances and repairs of the system with expired warranty period are carried out at the expense of the user on separate contracts between the user and the installer/service center.

Transportation rules

Products should be transported in the original packaging by any means of transport as long as they are protected from mechanical damage and precipitation.

Packaged products should be stored on racks in piles of 6 or less boxes, in enclosed, dry, heated rooms (no less than 1m from heating) which exclude possible interaction with moisture, oil products and damaging environmental factors.

Installation certificate

I, the undersigned _____

Position, name

professional installer, certify that installation of the service-security system, specified below, was carried out by me in accordance with manuals and schemes provided by the manufacturer

Car specifications:

Car model _____

Type _____

Id number (VIN) _____

Registration number _____

Security system specifications:

Model **Pandora DXL 0110L**

Serial number _____

Service center name, full address and installer's stamp _____

Signature: _____ / _____ / _____

Signator

Work accepted: _____ / _____ / _____

Signator

Date « ____ » _____ 20 ____ year



WARNING!
WE RECOMMEND YOU TO FILLING OUT INSTALLATION CERTIFICATE AND WARRANTY CARD BY INSTALLER. THESE DOCUMENTS MAY BE REQUIRED FOR CONTACTING CUSTOMER SUPPORT

Acceptance certificate

Pandora DXL 0100L is in conformity with Electromagnetic Compatibility Directive EMC 2004/108/EC and R&TTE Directive 1999/5/EC.

Serial number _____

Date of production _____

Responsible person's signature _____

(stamp)

Packager _____

Signature (personal stamp)

Warranty card

Model **Pandora DXL 0110L**

Serialnumber _____

Date of purchase « ____ » _____ 20__ year

Seller's (installer's) stamp

Seller's signature _____